

# ELECTRICAL COMMUNICATION

JANUARY

No. 3

1929

VOL. 7

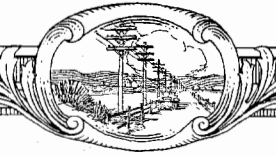

# ELECTRICAL COMMUNICATION

A Journal of Progress in the  
Telephone, Telegraph and Radio Art

## EDITORIAL BOARD

J. L. McQuarrie   F. Gill   G. Deakin   P. E. Erikson   G. H. Nash   M. K. McGrath  
G. E. Pingree   P. K. Condict   E. A. Brofos   E. C. Richardson   F. A. Hubbard  
H. T. Kohlhaas, Editor

Published Quarterly by the

## *International Standard Electric Corporation*

Head Offices

67 BROAD STREET, NEW YORK, N. Y., U. S. A.

European General Offices

CONNAUGHT HOUSE, ALDWYCH, LONDON, W. C. 2, ENGLAND  
75, AVENUE DES CHAMPS-ELYSEES, PARIS (8e), FRANCE

G. E. Pingree, President                      L. N. Rock, Secretary                      H. B. Orde, Treasurer

Subscription \$3.00 per year; single copies 75 cents

Volume VII

JANUARY, 1929

Number 3

## CONTENTS

PUBLIC ADDRESS DEVELOPMENTS..... 141  
By *W. E. Page*

MODERN MANUAL C.B. SWITCHBOARDS..... 147  
By *A. Capek*

A THEORETICAL STUDY OF THE ARTICULATION AND INTEL-  
LIGIBILITY OF A TELEPHONE CIRCUIT..... 168  
By *John Collard*

THE BOLOGNA ROTARY AUTOMATIC EXCHANGE..... 187  
By *Carl Chapperon*

INTERNATIONAL TELEPHONY ..... 190  
By *F. Gill*

ALLOCATION OF EUROPEAN BROADCAST WAVELENGTHS—  
SOME NEW POINTS OF VIEW..... 200  
By *Siffer Lemoine*

BROADCASTING STATION SQIG..... 210

SHEATH LOSSES IN SINGLE-CORE CABLES FOR THREE-PHASE  
TRANSMISSION ..... 211  
By *T. N. Riley*

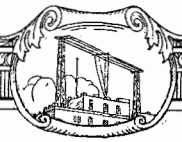



Frontispiece—H.R.H. Prince Arthur of Connaught Opening the Hall of Memory, Birmingham.



# Public Address Developments

By W. E. PAGE

*Standard Telephones and Cables, Ltd.*

THE article on Public Address Systems in Europe which appeared in a previous issue of *Electrical Communication*,<sup>1</sup> described progress to the latter part of 1924. Since that time the use of Public Address Equipment has grown to such an extent, that very few organisers of large gatherings of any importance attempt to complete their programme without this voice-amplifying device. Two historical and world-renowned buildings in London, the Guildhall and the Mansion House, are now equipped with permanent installations of the Public Address System. Practically every celebrity who has visited England has been entertained at one or other of these buildings, and a great many of these guests have spoken over the equipments fitted in the banqueting halls. In both of these buildings the equipment is that known as "No. 3," and is arranged by means of microphone switching panels to accommodate as many as ten microphones. The loud speakers are arranged in suitable groups, and are controlled by a switching and volume control panel, so that the proper set of loud speakers is brought into use for any particular speaker.

In November, 1924, there was given in the Underwriting Room of Lloyds Shipping Exchange, London, a demonstration of the No. 3



Figure 1—Lloyds Exchange. Underwriters Room Showing Loud Speakers.

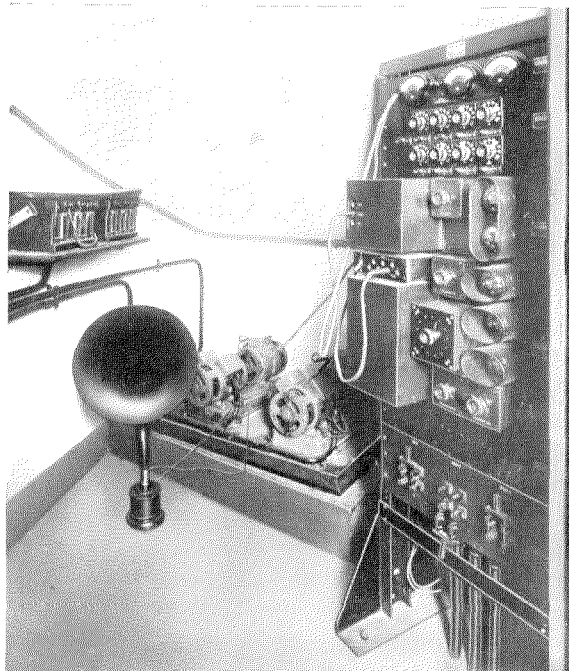

Figure 2—Lloyds Exchange. Control Room

System, which was installed to assist the Caller, who sits high in a rostrum announcing the names of underwriters who are in demand. The success of this demonstration was such that the equipment was adopted, and it proved so valuable in actual practice over an extended period, that in the palatial new Lloyds building (Figures 1 and 2), which was opened at Easter 1928, the larger No. 2 System was installed. Sixteen folded box-type projectors that serve the whole of the Underwriters' Room are suspended vertically from beneath the electroliers by means of a gilt rope with tassel falling over the box horns. The control room for this equipment, containing the duplicate double current motor-generator sets, is on the floor below the main hall, immediately beneath the rostrum in which is located the famous Lutine bell, which is tolled whenever a ship is posted as missing. When His Majesty the King laid

<sup>1</sup> "Demonstrations of the Public Address System in Europe," A. F. Rickard, *Electrical Communication*, Vol. 4, No. 2, October, 1925.

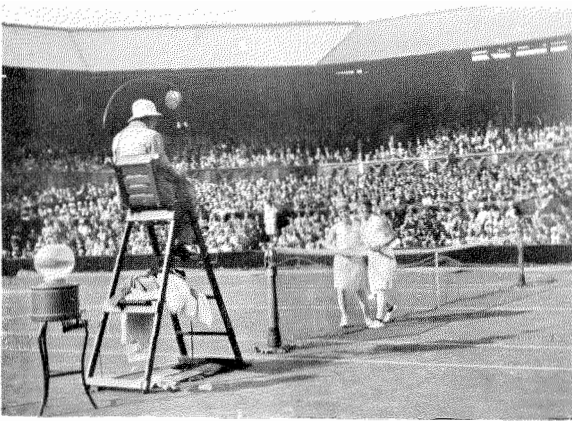

Figure 4—Wimbledon, 1927. The players are Fräulein Aussem and Betty Nuthall.

the foundation stone of this building on April 23, 1925, the amplifying of the addresses from the royal dais (Figure 3) to the large number of visitors accommodated on the circular grandstand built for the occasion, was effected by the No. 2 System.

The International Railway Congress at the Crystal Palace and the Railway Centenary Celebration at Darlington in 1925, where the No. 2 System was used, illustrate applications of such installations. At both of these gatherings hundreds of representatives from practically every country in the world were present.

The dedication and opening ceremony in 1925 of the Birmingham Hall of Memory to men of Birmingham who lost their lives in the war, was presided over by H. R. H. Prince Arthur of Connaught. A gathering of from 40,000 to 50,000 heard every word throughout a very impressive ceremony, by the aid of the



Figure 3—H.M. King George V Laying the Foundation Stone for Lloyds New Building, London.

No. 1 System. The large horns of the loud speakers (see Frontispiece) were mounted round the top parapet of the memorial, in correct relation to the area on the ground they were required to cover.

Scarborough, on the Yorkshire coast, has a special No. 2 installation. The equipment is installed on the "Spa," and is used for reproducing orchestral music and other items along the whole length of this promenade, into the various large cafés, and, when required, into the Central Concert Hall.

The orchestra can play either from the stage of the Concert Hall or from the Band Stand on the promenade itself. In bad weather the orchestra occupies the indoor position. A microphone is provided, however, for both positions, and it is only necessary to switch-in the appropriate microphone to distribute the music from either. Formerly, in the height of the season only about 2,000 of the 5,000 visitors could be accommodated with seating that would ensure proper hearing; for owing to restrictions imposed by sea-noise, and occasionally by mists, the Band Stand is screened for a considerable arc of a circle, with consequent restriction of seating space for perfect hearing. The equipment, therefore, has proved a great boon, for it has enabled visitors and townsfolk to hear at

all points along the Spa and elsewhere. Radio apparatus forms part of the equipment, and is used on occasions for broadcasting important radio items. The Spa equipment was used last year for the Annual Conference of the British Conservative Party which was held at Scarborough. The Prime Minister's address



Figure 6—London and North Eastern Railway. East Side of Station Showing Loud Speakers.

was sent from the Futurist Picture House over Post Office lines to the Spa, and was broadcast to approximately 14,000 people by the No. 2 equipment.

Liverpool Cathedral No. 2 installation<sup>2</sup> illustrates the possibilities of the Public Address apparatus in churches and cathedrals, which unfortunately generally suffer severely from echoes and reverberations, and serves, as an example of how difficult acoustic problems can be solved. Microphones are placed permanently at the Lectern and at the Bishop's Throne, also at the High Altar. At present eight box projectors are installed, and this number will be increased when the building extensions are completed. The system contains over 25,000 feet of lead-covered cable, all of which, with the exception of lengths in the airway ducts, is concealed by masonry work. As a result of the high quality of reproduction given by the equipment, installations have been made in several churches and cathedrals, the more important being

<sup>2</sup> "The Public Address System in Liverpool Cathedral," Ashley F. Rickard, *Electrical Communication*, Vol. 5, No. 2, October, 1926.

Worcester, Bristol and Norwich cathedrals. The smaller Special No. 4 Systems are installed in these instances.

The equipment used at the world-renowned Wimbledon Lawn Tennis Tournament (Figure 4), was widely appreciated; for previously, owing to the umpire's declarations being inaudible to many of the seat holders, they found it impossible to follow the games. No. 2 equipment was first installed on trial. There were many difficulties—including the fear, fortunately not substantiated, that the reproduction might disturb play on neighbouring courts—and officials were extremely pessimistic regarding results. The demonstration was completely successful, however, and from the Press, the officials, the players, and the public, it received exceptional praise.

Lunatic asylums do not at first sight appear to present very great possibilities in connection with Public Address equipments, but a definite sphere of usefulness has been found in this field. There has recently been installed a system in a mental hospital in Lancashire which has proved such a success and so valuable to the unfortunate

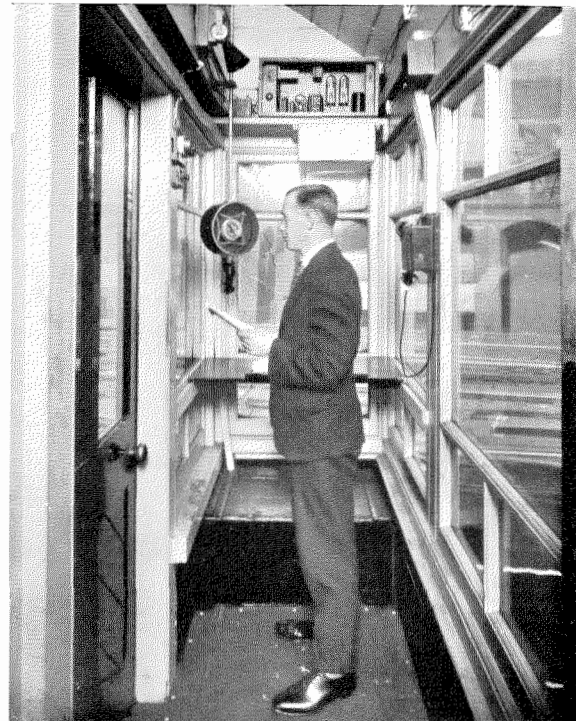

Figure 5—London and North Eastern Railway. Liverpool Street Station Control Room.

patients that mental authorities are inspecting the apparatus and its working, with the idea of introducing it into other institutions. Transmission is eagerly looked forward to by the patients, and every day the system is in operation spreading a little cheer among these unfortunates by means of radio items, local orchestral music, or their own church service. Almost immediately after this equipment was put into use, a request was made to provide apparatus for a similar institution, because of the good derived by the patients from the first installation.

A demonstration of an entirely different character took place on March 28, 1927, on board S. S. "Leviathan" in dock at Southampton. A banquet attended by over 600 people was held

inadequate. Recent successful demonstrations carried out at York, Newcastle, London Bridge and Scarborough have created quite a sensation at the Railway Headquarters, and equipments have been ordered and installed at both Liverpool Street Station, London, and Barry Island Station, Wales.

In the case of the London and North Eastern Railway, the system which has been installed at Liverpool Street Station and which is shown in part in Figures 5 and 6, possesses several very important features. The suburban traffic handled at this terminus is greater than that at any other station in the world, the daily passengers being over 250,000. Notwithstanding the great handicap of its being a "bottle-necked" station,

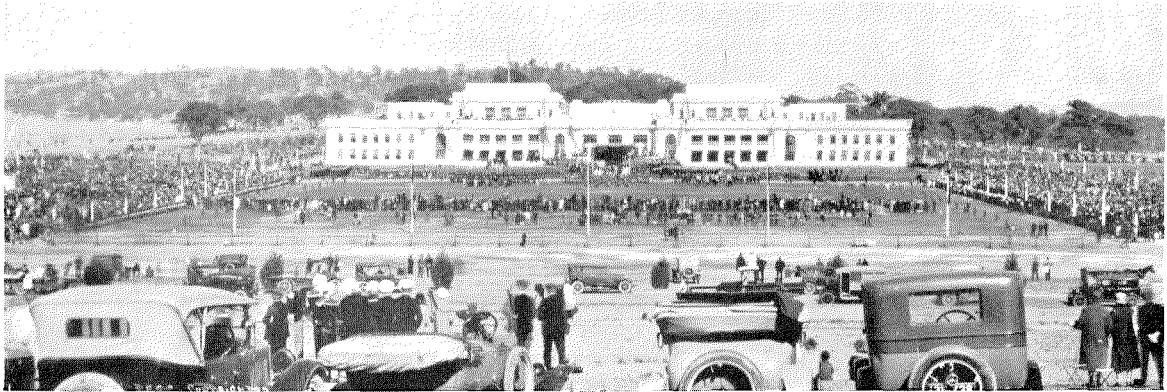

Figure 7—Federal Parliament at Canberra, Australia.

to commemorate the one-hundredth crossing. The system was installed to allow the speeches to be heard in every part of the main banqueting hall. A telephone conversation between officials in New York and the Chairman, via the Transatlantic Radio Circuit, was repeated as received, over the Public Address System.

The latest development associated with Public Address apparatus is an equipment arranged for the use of railway companies for train announcements at busy stations. On all lines, great difficulty is experienced at certain of the larger stations in the distribution of explicit directions to the traveling public respecting the departure and arrival of trains. At many of the main stations, it is found necessary to modify existing arrangements at the last minute, and the existing facilities for advising the public quickly of these rearrangements have always been recognized as

having only three pairs of lines in and three pairs of lines out, the eighteen platforms handle 1,215 steam trains per day, with 150 seaside specials on Saturdays. The organization is such that a two-minute up and down service on one line and a three-minute service on the others is maintained.

Loud speakers (Figure 6) are distributed over the east and west sides comprising eighteen platforms. The control equipment (Figure 5) is in an annex to the main signal cabin, from which is marshalled either directly or indirectly, every train entering or leaving the station.

Important demonstrations were carried out at Belfast and Blackpool on May 19 and July 6, 1928, respectively. At Belfast, the speeches at the ceremony of the laying of the foundation stone of the Houses of Parliament for Northern Ireland were successfully amplified to a gather-

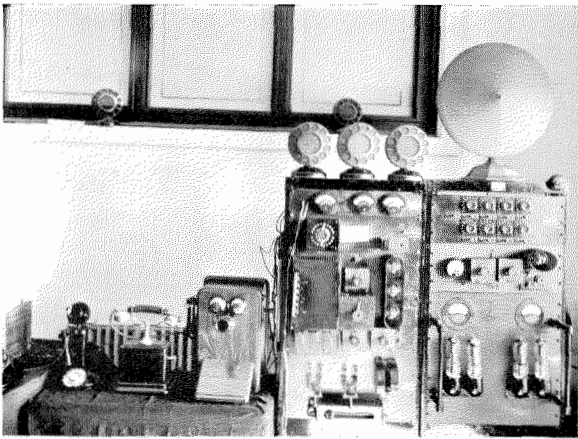

Figure 8—Federal Parliament at Canberra, Australia, Control Room.

ing of over 80,000 people. In the case of Blackpool, throughout the Air Pageant, over 120,000 people were kept in touch, by means of the No. 1 System, with every detail of each event, and with the musical programme from the Military Band. This was the first public occasion in England on which the high efficiency moving coil type loud speaking receiver, known as the No. 555-W, was adopted for such a purpose. Congratulations received from all quarters testified to the excellence of this latest type of receiver.

At the opening of the Federal Parliament of Canberra, by His Royal Highness the Duke of York on May 9, 1927, the No. 1 System made it possible for over 100,000 people to follow the ceremony by hearing perfectly every word

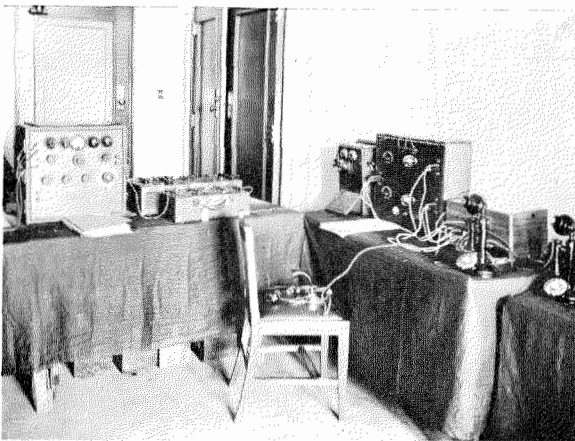

Figure 9—Federal Parliament at Canberra, Showing Apparatus Used for Broadcasting Telephone System.

addressed to any one of the seven microphones. Not only did that system provide the local amplification, but, to obviate the necessity for the duplication of microphones, it was arranged with the Australian Postmaster-General's Department, that the power input to the broadcasting telephonic network should be taken off one of the output circuits of the Public Address System, thus obviating the duplication of the amplifier system, and permitting of one control. The extent of this part of the system is shown in Figures 7 to 10, inclusive. The route length of lines comprising the network was 1,775 miles. The broadcasting covered a reception area of approximately 1,000,000 square miles, and it is estimated that by this means approximately 2,000,000 people listened to the ceremony.

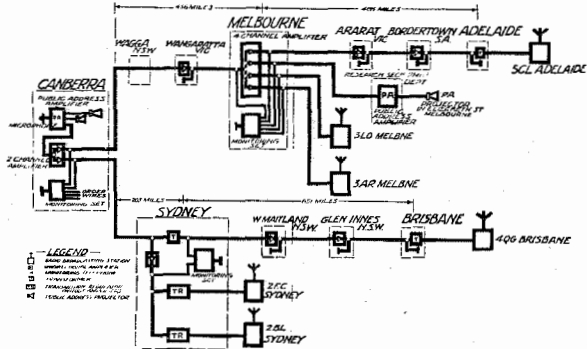

Figure 10—Federal Parliament at Canberra. Plan showing diagrammatic layout of System.

Figure 8 illustrates the Public Address equipment. It also shows the monitoring loud speaker and observation telephones. The apparatus for the broadcasting telephone system was placed in the same room, and is shown in Figure 9. By the courtesy of the Australian Postmaster-General's Department, a brief description of this equipment can be given.

Mounted on the table in the foreground is the special two-channel amplifier, and the monitoring set (Figure 9). The two-channel amplifier was specially designed by the Research Section of the Australian Postmaster-General's Department, and its input impedance was such that it in no way affected the operation of the Public Address System. Each channel of the amplifier had a separate potentiometer for controlling its gain. The monitoring set was designed to



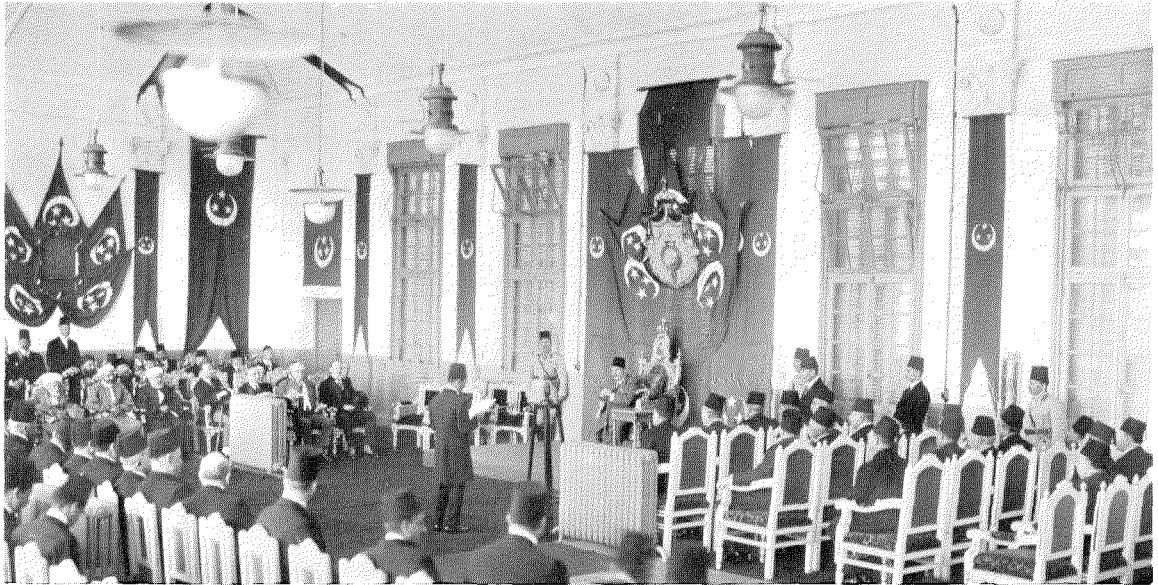

Figure 12—Opening of the Medina (Egyptian Parliament.)

give the broadcasting control engineer instant communication with all strategic points of the system from Brisbane to Adelaide. On the second table is mounted an oscillator and transmission measuring set, used during the preliminary tests for making an overall check of the transmission power levels on the Canberra-Brisbane and Canberra-Adelaide circuits.

The best testimony of the efficient working of the Public Address System is perhaps to be found in its appreciation by enormous crowds—for example, such as listened intently to the running commentary of the football match

between Belgium and Holland played recently at Amsterdam (Figure 11). The order and interest displayed by the listeners, prove the effectiveness and value of the system.

Public Address apparatus has penetrated practically to every country in the world. The opening of the Medina, the Egyptian Parliament, is depicted in Figure 12, which shows King Fuad in the Chair being addressed by H.E. Ahmed Khashalia Pasha during the opening ceremony. The peculiar shape of the building made it necessary to place the projectors in the high roof and arrange for eliminating echo effects.



Figure 11—A Section of the Crowd Listening to the Description of a Football Match in Progress Between Belgium and Holland at Amsterdam.

# Modern Manual C.B. Switchboards

By A. CAPEK

*Bell Telephone Manufacturing Company*

## Introduction

THE Common Battery manual exchange system was developed during the years of 1892-1898 by the engineers of the Western Electric Company and the American Telephone and Telegraph Company, and was known originally as the No. 1 Relay System.

The success of the No. 1 C.B. board was without parallel in the history of the telephone art; there has never existed and probably never will exist any other type of telephone exchange so widely used for so many years in practically its original form. For about twenty years this board held its prominent place, during which time other competitive systems were developed, tried out and discarded. It was the demand for a more efficient type of exchange for large multi-office areas that put the automatic system in the leading place occupied by the C.B. manual board up to that time.

All of this belongs, of course, to the history of the telephone art. The general introduction of the automatic system has changed entirely the character of the switching problem, and the requirements which manual boards must meet. The automatic exchange system has enjoyed many years of steady progress, as the leading telephone exchange system. The time is opportune, therefore, to review the situation and to see how the spread of automatic operation has affected the position of the C.B. manual system, and what chances for future use are left to it.

The International Standard Electric Corporation, because of its close contact with conditions in all parts of the world, is in a particularly advantageous position to consider the present aspects and future prospects of the C.B. manual system and to determine its sphere of usefulness in the operating field. In this connection it is interesting to recall that the C.B. board with its original 1898 features was considered, during its period of competition with the automatic, as being at the highest point of its development. There also was a time when many competent

telephone engineers asserted that the victory of the automatic system would mean the certain death of the C.B. system. Both of these assumptions have proved to be incorrect.

It is obvious that, due to the extended use of the automatic system, the general demand for manual equipment has decreased rapidly; but it is also a fact that there still remains a well defined field of application for C.B. manual boards for isolated plants up to several thousands of lines, where comparative simplicity, low first cost and cheap maintenance are factors of first importance.

The introduction of the automatic type of exchange, on the other hand, has had an excellent effect on the standard C.B. exchange systems. Prior to its advent, manual boards were, of course, improved in some respects and new features, which either simplified the work of the operator or distributed subscribers' calls more efficiently among the different operators, were introduced. Automatic ringing and listening, and the use of auxiliary or ancillary line lamps will serve as examples of such advances. But the radical departure from so-called standard practice only started when it was realized that many of the features of the automatic system, if applied to manual exchange conditions, would also greatly improve the manual service, and increase the operator's loads.

The result of the work in this direction was the development of the so-called high efficiency board (sometimes called superservice board), which will be described later. This improved type of C.B. board, which made it possible to give the subscriber a very much better service, did not, however, entirely eliminate the demand for simple C.B. boards; the manufacturing companies, therefore, were required to make arrangements for furnishing both types; viz., the original C.B. type, and the high efficiency C.B. board.

Preliminary to a somewhat detailed description of the circuit and other features, it is desirable to consider the question of the capacity of the

modern C.B. manual board. Formerly it varied from about 300 to about 10,000 lines. C.B. boards under 300 lines were not economical because of the comparatively high cost of the power plant; boards over 10,000 lines required a smaller jack, and, therefore, increased the maintenance cost.

The advent of the automatic system and the later improvements in the manual board changed both of these limits. Present experience indicates that all multi-office areas and single exchange areas likely to require branch offices in the near future are best served by full automatic systems, but for isolated single offices in undeveloped countries up to an ultimate capacity

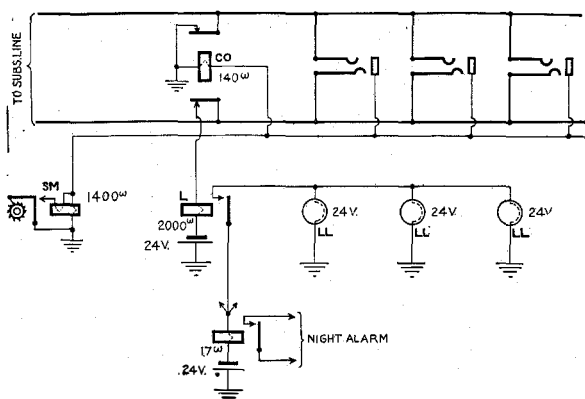

Figure 1—Subscriber Line Circuit.

of roughly 5000 lines, there remains a good field for manual C.B. boards.

The more extensive use of portable accumulators, the development of primary batteries of large capacities, and the use of current saving telephone circuits, made it possible to justify economically C.B. boards for exchanges smaller than 300 lines. Small capacity batteries only are necessary, since a manual non-multiple board equipped with a relay condenser cord circuit and subscriber cutoff jacks consumes practically only the current needed for the subscriber transmitters, the current required for signaling purposes (lamps, etc.) being insignificant. On such boards the talking current is comparatively low (with high resistance transmitters, it is 50 milliamperes, or even 20 milliamperes on an average, according to the transmitter and the cord circuit current supply bridge used); and the current consumption for an average 2-minute local conversation is, therefore, but 0.0035 or

0.0015 ampere-hours, respectively. For this reason, even a set of primary cells of 250–500 ampere-hours capacity may satisfactorily supply for several months the necessary current for C.B. exchanges up to 100 or 200 lines.

The restricted field for the C.B. boards, and the smaller capacity of these boards, has also affected the construction of the switchboard section. The standard 3-position section is practically no longer built, being replaced by simple 1-position sections. The latter are more flexible where existing rooms are to be used for housing the exchange and they have the advantage of a cheaper iron construction. Moreover, they are more easily handled in shipment and are preferred to the older types for both the simple C.B. and for the superservice systems. The construction of such boards does not differ very materially from the earlier type of 1-position boards.

With these remarks as an introduction, a more detailed description of both types of manual boards, of their operating features and of the circuits employed to meet the different conditions, will be given.

### 1. Simple C.B. Manual Boards

This type of switchboard employs the circuits of the old standard No. 1 C.B. board to a limited extent. In case a current-saving arrangement is required, the supervisory relays are equipped with a back contact; and, instead of being shunted as with the No. 1 C.B. board, the supervisory lamps are short-circuited as soon as the supervisory relays operate.

If a condenser-relay transmission bridge is needed, a cord circuit with condensers in both talking leads, and supervisory relays with double windings, may be employed.

For very small boards (non-multiple), the subscriber's line cutoff relay usually is replaced by the cheaper cutoff jack.

A separate intermediate frame may be used but, since the size of the manual exchange is now comparatively small, a combined main and intermediate frame is as a rule preferred.

The operating features and other characteristics common to all such boards are:

1. Repeating coil or relay condenser transmission.

2. Manual listening and ringing.
3. Line relay is cut off from the line as soon as a plug is inserted.
4. Two combined supervisory and clearing out lamps, with positive action, under switch-hook control. The lamp associated with the calling plug lights during the ringing period and serves as a guard signal.
5. Capacity busy test, and anti-sidetone induction coil.
6. Pilot lamps for the line signals, but none for supervisory lamps.

rather to speed up the service by the introduction of features tending to simplify the work of the operator, regardless of the consequent circuit complexity and the larger amount of apparatus involved, the extra initial cost being compensated for by annual charge considerations.

Although the first types of the improved C.B. boards were built in America, the European development of a similar type of board for Europe has had to form the subject of independent study, because the operating requirements, such as those in connection with "toll

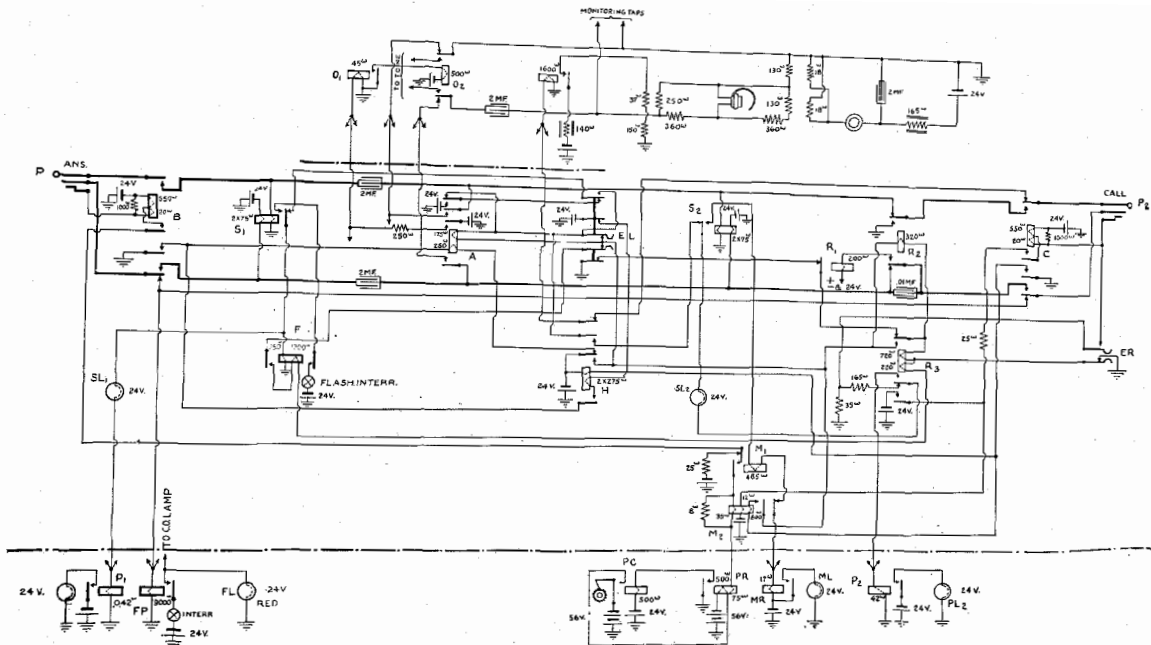

Figure 2—Subscriber Cord Circuit.

The circuits involved are all very well known, and have been used successfully in a very large number of exchanges for a period of nearly thirty years. Both as to operation and service as well as to flexibility, simplicity, low first cost, cheap maintenance and low annual cost, they have proved satisfactory.

## 2. High Efficiency C.B. Board

Whereas the boards just described, by the retention of practically all of the features common to the No. 1 C.B. system, are designed for a minimum of apparatus and simplicity of circuits compatible with good service; the high efficiency boards, on the other hand, are intended

preference" or the limited demand for measured rate service or party lines and the importance of secret service, are in certain respects radically different from those in the United States.

The questions and problems which must be considered in connection with such a modern C.B. board are numerous. It is, therefore, advisable to investigate all of the operating possibilities systematically for every step of the connection and to note how the different possible solutions satisfy the various demands of telephone administrations. In this manner, it is possible to arrive at the requirements which a high efficiency board has to fulfill.

To investigate in their proper sequence the different problems involved, the whole switching



work of the operator will be divided into its elements and each considered separately.

Such elements, for any regular connection, are the following:

- (a) Calling.
- (b) Answering, plugging up the calling subscriber, and taking the order.
- (c) Testing for busy.
- (d) Connecting to the called line and ringing.
- (e) Talking, and
- (f) Clearing out with disconnecting.

There are also the irregular calls:

- (g) Recalls, and
- (h) Preference toll calls.

(a-1) Since the present paper does not deal with automatic distribution, only systems where the subscriber's line ends in a jack and a calling lamp will be considered.

In the standard manual board the line lamp appears as a rule only before one operator, who with her immediate neighbours makes a working team of three. Subscriber lines are as a consequence divided into comparatively small groups and the number of calls arriving at each group varies considerably during any time period.

Different manual schemes were developed to correct the uneven distribution of calls and were put into service, though with more or less success, such as the auxiliary or ancillary

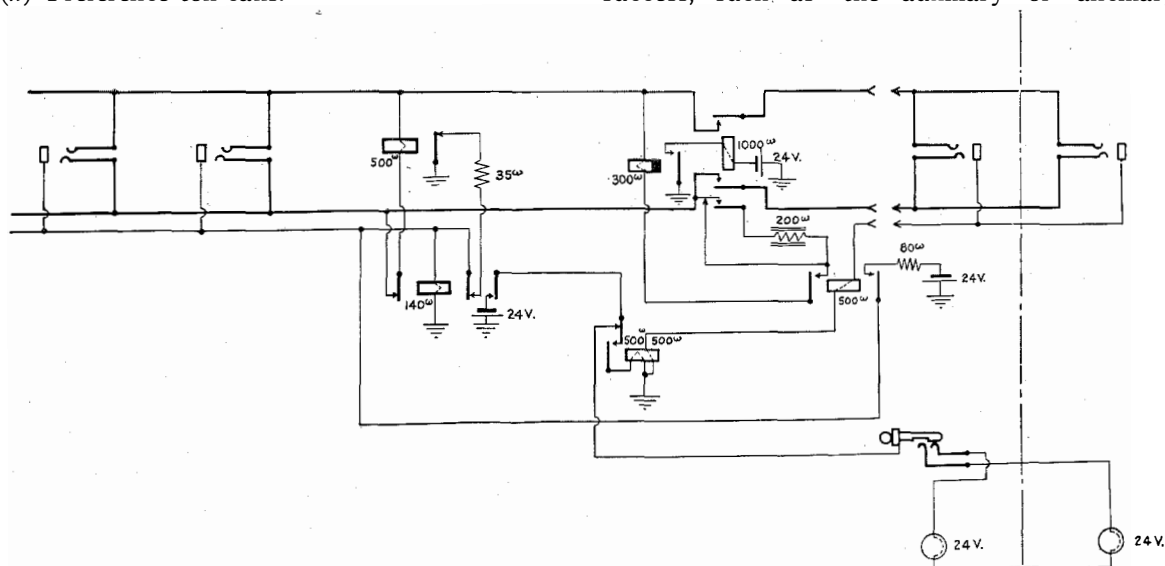

Figure 3—Recording Trunk Circuit.

In addition, there are the different kinds of special services and other features, such as:

- (i) Subscriber's call metering.
- (j) Counting the operator's connections (peg count).
- (k) Party line and coin collect service, and
- (l) Pilot lamps.

(a) *Subscriber Calls:* There are three separate phases which must be considered in connection with this operating element:

- (1) The kind of signal used to attract the operator's attention.
- (2) The application of busy condition to the calling line.
- (3) The arrangement of pilot signals.

answering jacks and lamps, overflow circuits, manual distribution, etc. But of these, the only arrangement which survived was the system with multiple calling lamps. With this scheme, the calling lamps are multiplied over the whole exchange and are associated with the multiple jacks, but the usual answering jacks and lamps, together with the answering cable-runs, and the I.D.F., are omitted.

It is interesting to note that this simplest and only practical solution of the distributing problem was the last one to be put on trial. But this may, of course, be accounted for by the unwillingness of telephone engineers to sacrifice valuable multiple jack space for the line lamps. For this reason, the multiple lamp

system could only be evaluated after the capacity of manual boards was restricted to 5,000 lines.

The advantages of this multiple lamp system may be summed up as follows:

(a-1-1) It is a very efficient system of distribution, as every calling signal is displayed before all operators. In this way a large number of subscriber lines (usually 1,000 or more) can be served in one group having a comparatively uniform flow of calls for any given time interval. Operators serving such uniform traffic can readily handle larger loads than in the normal C.B. system, without increasing the answering time.

operators in all cases carrying a full load with standard answering time.

(a-1-3) The additional equipment necessary is comparatively inexpensive; the cost of the calling lamps is practically offset by the saving of answering jacks and cables and the intermediate distributing frame.

It is true that the cost of the local cord circuit must be increased to provide means for the first operator who reaches a calling subscriber, to block out any other operator who may have tried to answer the same call. Two marginal relays per cord circuit are needed for this purpose, but these relays serve also for

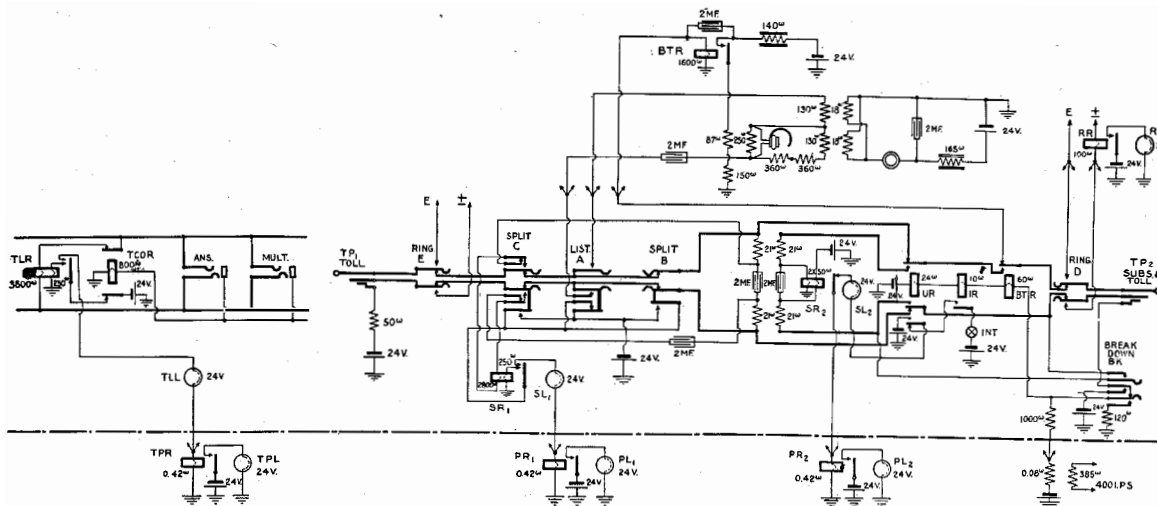

Figure 5—Toll Line Circuit.

Figure 4—Toll Cord Circuit.

The system permits multiple line lamps to be added through the entire multiple, so that a call is placed before all operators. It is found, however, in practice, that no gain is secured beyond five multiple line lamps—an arrangement which places the call before fifteen operators. The high efficiency exchange of more than fifteen operator positions is, therefore, split up into two or more parts, with the line lamps multiplied in one part only.

(a-1-2) The multiple lamp system is very flexible as regards both the normal and abnormal variations of traffic. It makes it possible, therefore, to reduce or to increase the number of operators according to the traffic, without any change or rearrangement of the equipment. Part or full concentration, night service or specially heavy loads, may be easily handled,

the breakdown of local connections for toll preference.

(a-1-4) The increase in operators' load makes it possible to reduce the number of operators for a given traffic. There is consequently a saving in position equipment, multiple sections, floor space and operators' wages.

The drawbacks of the multiple calling line system, compared with its good points, have proved in practice to be only of theoretical significance.

(a-1-5) The most conspicuous disadvantage is the reduction of the multiple jack field capacity. It is true also, that the multiple lamp scheme in actual operation is of little value for small boards of less than six operators, but in practice it is potentially useful even for a group of three operators, because a satisfactory

size of the group may be reached during the growth of the exchange. On the other hand, groups that are too large would be superfluous; for, teams of more than fifteen operators would not produce any additional equalisation of the load while the additional multiple line lamps would only increase the height of the board and, of course, also its first cost. For this reason the system is limited to exchanges with capacities of 300 to 6,000 lines. Exchanges larger than 3,000 lines are best split into two

number of cord circuits in a high efficiency exchange, due to the smaller number of operators' positions needed, is, of course, less than the total number of cords in a standard C.B. exchange handling the same traffic.

(a-1-7) There are two more points which sometimes are brought forward against the multiple lamp system: the greater current consumption due to the multiple lamps, and the duplication of operator's work in case more than one operator attempts to answer a call. Both



Figure 6—Operating Room—Subscriber boards on the left side, toll boards on the right side.

groups (with a cable box between them). The complete multiple appears in both groups, but multiple lamps are provided in each group only for one-half of the lines.

(a-1-6) It might be surmised that the increased load per operator involves an increase in the number of "A" cords, but careful calculations, checked by actual traffic tests, have shown that such is not the case. The uniform load possible with the multiple line lamp, and the large number of operators in one group, increase the connecting efficiency per cord, so that the number of cords per position is the same as in the standard C.B. board. The total

of these disadvantages are unimportant, as may be seen from the following:

The line lamp circuit consumption is very small when compared with the total current needed for a conversation. The current for the extra lamps is largely balanced out by the absence of the line pilot lamps, which are no longer needed, and by the shortened time of burning through quicker answering.

The duplication of effort, through attempting to answer a call already picked up, is insignificant when compared with the total work of the operator. It is found in practice that the operator does not actually plug a jack before dis-

covering she is too late. Ordinarily, she notes the line lamp aimed at disappearing and simply picks a neighbouring signal with practically no loss of time. But if she does plug in, she immediately obtains a signal (acoustic or visual, as will be explained later), thus avoiding any further loss of time.

(a-1-8) Another objection, which proved largely theoretical, to the multiple lamp system is the point of divided responsibility. It is found in practice that operators inclined to hold back the answering of calls are speeded up by their more industrious colleagues. Furthermore, automatic peg count meters enable the chief operator to compare the operator performance and to locate laggards.

(a-2) The next question to be considered in connection with the calling period concerns the application of the busy test to the calling line. The standard manual board makes the calling line busy at the moment when it is plugged up by the answering operator, whereas in the automatic system the calling line is made busy for all incoming calls practically at the moment the subscriber removes his receiver from the hook to make his call. There arises therefore the question whether the latter practice should be adopted also for the high efficiency board.

The delayed application of the busy test has certain disadvantages. In exchanges with a large number of heavily loaded P.B.X. lines and a comparatively low grade of service, it may happen that a P.B.X. subscriber is connected to an incoming call before the answering operator has picked up his line and made it busy. Such connections are particularly annoying, because the P.B.X. subscriber must obtain the attention of his P.B.X. operator—not usually an easy matter—to explain what happened, and to ask her to attend to the new incoming call from the exchange. The results may be even more complicated when two P.B.X. trunks are thus connected. While such connections are rare, they are inevitable with the standard busy test.

Multiple lamps require the operator's bar, and this is secured by arranging for the first answering operator to alter the potential of the test sleeve, so as to make the blocking feature of the other cord circuits connected to the line operative. Such a condition is, of course,

contradictory to the simultaneous busy test. The problem is further complicated by the automatic breakdown of local connections for toll preference which must also be effected over the third conductor.

As a result of the considerations mentioned, it was found advisable to retain the busy test method of the No. 1 C.B. board for the high efficiency board. The small disadvantage of such a test is in any case lessened on account of the greatly shortened answering time on the new board.

(a-3) The last question to be considered during the calling period is the necessity for the equipment of pilot lamps.

In the multiple line lamp boards the pilot lamps, if provided, would light up during the greater part of the time and, since they serve no useful purpose, they are best omitted.

(b) *The operator plugs in and answers:* This period may be divided into the act of plugging up the calling line and the act of connecting the operator's talking set to it. But as in some systems both of these operations are effected simultaneously, it is preferable to consider them both at the same time.

The insertion of the answering plug into the subscriber jack, applies the busy test to the line. At the same time the operator's bar or lock-out must be placed on the line. The cord circuit must be further arranged so that a signal (audible or visual) may be given to another operator who is too late in answering the call.

The operator's bar requires a special relay for every cord, adjusted to distinguish between a busy and a free line, and to connect, or disconnect, the cord circuit apparatus according to circumstances. The connection of the operator's set to the cord circuit may be performed in either of two ways; viz., by means of a key or, automatically, a relay. Automatic or keyless listening saves operating the listening key and requires only one additional relay per cord circuit.

The advantage of "advance plugging" may be considered at this point:

In the standard C.B. boards, the operators are accustomed to plug out a second calling line while answering the first call. In the high efficiency board, the answering time is so short that it seems undesirable to encourage such



practice, and the cord circuits should therefore make such "advance plugging" impossible.

(c) *Busy Test:* In the design of the high efficiency system, the question of improving the standard C.B. manual click test was given careful consideration. Visual signals were proposed and abandoned. The automatic busy test used in some types of incoming trunk boards presented many advantages. In this, the operator simply plugs in; the apparatus of the cord circuit tests for a free or busy condition of the line, connects in the first case to the calling line and in the second case to a busy tone for the information of the calling subscriber.

The automatic busy test can readily be applied to the high efficiency board, but it was deemed inadvisable for the following reasons:

It would increase the average holding time of cord circuits and therefore also their number because the subscriber is always slower to hang up his receiver in response to a busy tone than if he gets the verbal information from the operator, especially if he also must distinguish other tones, as for example, the ring back tone.

The testing of a P.B.X. trunk group requires manual click testing to find the idle line in the group even when the automatic busy test is employed. The manual click test furthermore allows the subscriber to ask at once for a second number, thereby avoiding delay and saving the operator's time.

It is recommended, therefore, that the standard click busy test be utilized in the high efficiency board.

(d) *Connecting to the called line and ringing:* This operating period consists of two independent parts:

(1) The insertion of the plug into the called line jack, an operation which prepares the connection, makes the called line busy and cuts off the operator's set automatically, provided keyless listening is used, and (2) The application of ringing current to the called line and a display of some sort of a ringing guard signal.

The application of the busy test raises the question whether the operator's bar recommended for the answering cord should not be provided also for the calling plug.

This arrangement is not imperative for the calling cord, because it is improbable, except in the case of busy P.B.X. trunks, that a group of

operators would try to connect to a line at the same time. For this reason also the boards of American origin are not arranged for such operator's bar, but for the European subscribers this feature is usually specified, the relay required per cord circuit serving also for the automatic breakdown from toll and for secret service. The operator's bar on the calling cord possesses certain operating advantages, in that it prevents double connection, due either to careless operating methods or to simultaneous testing on very busy subscriber lines (P.B.X. trunks).

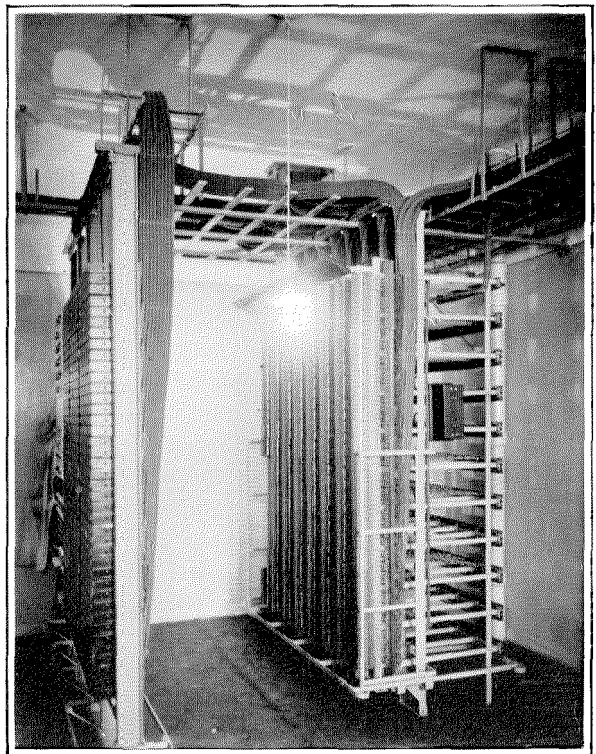

Figure 7—Apparatus Room—Distributing frame with line relay rack (front view).

(d-1) As regards ringing on the called line, either manual or automatic types can be provided:

Automatic ringing simplifies the work of the operator, especially during the ringing period. The operator is relieved of all supervision, and does not have to respond to recalls from the calling subscriber for a re-ring. It has been found, in service, that the additional comparatively high cost of this feature (three relays

per cord circuit) is justified in all single district offices and in offices with small trunking traffic.

To make automatic ringing successful, it is necessary to give the calling subscriber some sort of a signal during the automatic ringing period, so that he may control the progress of the call, and satisfy himself that the delay in answering is not due to operator carelessness. In case the call is abandoned, it is also important to cut off automatically the ringing current when the calling subscriber replaces his telephone receiver. Furthermore, automatic ringing must be arranged to be cut off the instant the called subscriber takes the receiver off the hook, in order to prevent ringing in the ear of the subscriber, or the sending of ringing current through the transmitter button.

(d-2) The ringing guard signal was given much study. In the standard No. 1 C.B. board, the calling supervisory signal remains lighted during the whole ringing period. In European boards of the same type, a ringing pilot lamp is added, as a rule, which lights while the ringing current is sent over the line; that is, during the operation of the ringing key. Such a signal shows the operator that ringing current is flowing, and that the line is not open. In the case of automatic ringing, this problem is somewhat complicated. It is agreed that the operator must know that ringing current is flowing, particularly because the automatic ringing relay may have tripped due to a momentary earth (in the protector, etc.) and disconnected the ringing current. A ringing guard signal, therefore, is required, but it must differ from the clearing out signal. The most economical way to obtain this result is to let the calling supervisory lamp burn dimly during the ringing period, and brightly as a clearing signal. In this way a practically dark keyshelf is obtained, and there is a guard which cannot be misunderstood on the called line. Inasmuch as the additional cost of this arrangement is comparatively very small, it was found advisable to adopt it for all high efficiency boards for Continental use.

(d-3) The questions of party line ringing, and the re-ring in case of recalls are discussed hereinafter.

(e) For the supply of current to subscribers, only the two very well known types of trans-

mission bridges may be applied: the repeating coil or the condenser-relay arrangement. Both types have certain advantages, so that it is advisable to be prepared to furnish either for the high efficiency board according to local conditions (type of transmitter used, etc.), or the specified requirements.

(e-1) The so-called "secrecy" feature, which in a broad sense makes it impossible for the operator to listen-in on a talking connection, has found much favour in Europe, owing to the less efficient supervision in the average European telephone exchange. For this reason all high efficiency Continental boards are arranged for secrecy. This requirement seems to be well defined, but actual experience has shown that there are different grades of it; viz., nominal and actual secrecy.

For nominal secrecy it is sufficient to let the supervisory relays control the connections of the operator set to the cord circuits. But the operators usually discover ways for circumventing this type of secrecy, such as by using a second cord. It, therefore, has been necessary to equip all the high efficiency boards of the European type for "actual secrecy," which makes it practically impossible for the operator to listen-in on a connection.

To secure such secrecy, it is necessary to provide the operator's bar for both cords of a cord pair, and, further, to take particular care that the operator cannot listen by throwing two keys of different circuits (where emergency keys are provided) or by plugging one of the plugs in a dead line.

(e-2) There is, however, one eventuality when the operator must enter in on a connection during the talking period, in spite of the secrecy feature, that is, in case of recall or breakdown from the toll exchange, and the circuits of the high efficiency board must be arranged to make this possible.

(f) *Clearing out with disconnection:* There are really but two distinct methods of disconnection in manual exchanges: the "manual disconnect," by taking down the cords, and the "automatic disconnect," in which the talking conductors of the cord are automatically opened, when the subscriber restores his receiver. In the manual method, the subscriber's line remains busy until the operator takes down the cords. In the

automatic method, the line is made free as soon as the subscriber hangs up his receiver; in other words, the subscriber who originated the call (or exceptionally also the called subscriber) controls the connection.

In the manual disconnect, the recall signal appears on the cord circuit used for the connection, so that the original operator, who answered the call, also handles all "recalls." In the automatic system, a recall will appear on the

be able to attend to a recall (for example, if the subscriber should request his party to be rung again, in case of operator's bar on both cords) and would have to wait until the original connection was taken down.

Another difficulty is encountered with the automatic type of disconnection, in case a measured rate subscriber gets a wrong number, either due to his own or to the operator's fault; here again, only the operator who originally

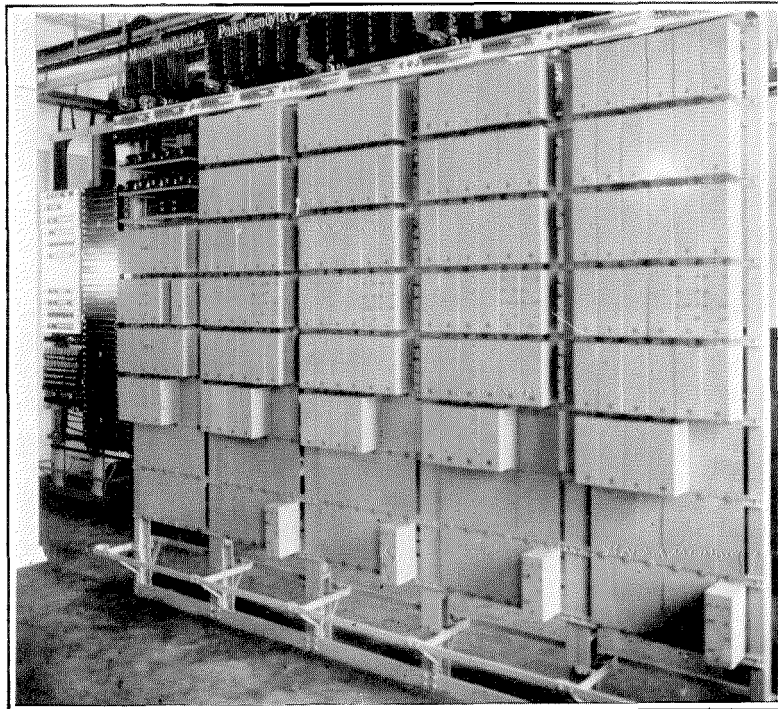

Figure 8—Apparatus Room—Cord circuit relay rack with fuse panel (front view).

multiple line lamps as a new call, with the probability that another operator, who knows nothing about the original call, may pick it up.

The shorter time during which the calling subscriber's line is kept busy, is certainly an advantage of the automatic disconnection, but this "line lamp recall" feature also has its drawbacks. In case a manual subscriber flashes the operator (because he has received a wrong number or because he wants her to ring up his party again, or in case he has moved his switch-hook by mistake), it is advisable that the recall should be handled by the original operator who can deal with it intelligently and promptly. Furthermore, a new operator would not always

attended to the first call can properly take care of it and meter it correctly.

It is true, of course, that in automatic exchanges no difficulty is encountered in a similar case, but it must be remembered that the general feeling of subscribers in a manual system is entirely different from that of subscribers in an automatic system. A subscriber in a manual system, in general, tends to attribute mistakes to the operator whereas the subscriber in an automatic system usually is quite certain that calls that go wrong are due to his own mistakes.

From the preceding, it is apparent that the automatic disconnecting system may be considered advantageous only from the viewpoint

of making the calling line free more quickly, and that in all other respects, the manual disconnecting system is superior, especially where a double-sided operator's bar is specified and where the calls are metered. It is, therefore, preferable to arrange the high efficiency board in Europe for manual disconnecting, and to consider the automatic disconnecting system in special cases only where subscriber message registers are not employed.

(g) *Recall*: The usual type of recall in connection with the manual disconnection system, that is, the flashing of the supervisory lamp in accordance with the movement of the subscriber's hook, is not a very efficient way of gaining the operator's attention, as the operator may easily overlook it when she is very busy, because of the absence of any special signal after the flashing period and because the signal may be indistinct in case the subscriber moves the switchhook very quickly. For these reasons it is advantageous to make the flashing recall positive and visible. It should be set by operating the switchhook once, and maintained until the operator answers. Such an "automatic flashing recall" signal as a rule is applied only to the answering cord, where recalls usually occur (up to 10 per cent of the total calls against 1 per cent from the called subscriber).

In the case of an inadvertent movement of the switchhook, the automatic flashing recall will, of course, make it necessary for the operator to enter in the connection. The number of such false calls is, however, extremely small.

The recall requirement may, of course, clash with the secrecy feature; the operator in response to a recall, therefore, must be in a position to break down the secrecy, as it may happen that the second party may remain at the telephone.

The simplest solution would be to let the operator remove the calling plug, and get automatically in connection with the calling line. This procedure is admissible, as the operator must remove this plug in most cases of recall. If, however, the called subscriber remains at his telephone, this act would display a false line signal along the board. To prevent such a false call, the operator preferably removes the answering plug and replugs with the answering plug of an idle pair. Very often it is deemed

necessary to install special emergency listening keys for this purpose, but such equipment is, of course, optional.

(h) *Toll calls for local busy subscribers (preference toll calls)*: There are three different ways of handling incoming toll calls for subscribers who are engaged locally. The toll operator waits until the subscribers' line is free (American method), breaks the local connection in preference for toll (European Continental method), or first offers the toll call to the subscriber talking locally, and the local connection is broken only if the subscriber agrees to accept it (English method).

The European telephone administrations usually employ the second (breakdown) operating method, for the reason that the number of toll lines available is very limited and it is, therefore, necessary to employ all possible means to improve their efficiency.

The standard C.B. system provides for this toll preference service in several ways, the most expensive arrangement consisting of a cutoff jack (or a parallel jack with a cutoff relay) for every subscriber line in the toll switching section. This switching method was formerly very popular in Europe, as it was possible to break positively the local connection at any time and also to disconnect the switchboard multiple cabling from the toll connection.

Another solution of this problem is to use parallel multiple jacks in the toll switching section, in connection with switching trunks which are arranged to permit the toll operator to flash the supervisory lamp of the local cord, making the line "locally busy," thus giving a peremptory disconnect signal to the local operator. With this arrangement the toll operator is, of course, dependent on the local operator for a prompt response.

The high efficiency boards possessing the operator's bar are particularly well adapted for toll preference connections, because relays needed for non-interfering answering can be used also for disconnecting the local cord circuit from the subscriber line which is required from the toll board. This toll breakdown feature is, of course, needed both for the answering and the calling cords; and to get the full value of it, it is recommended that the following additional operating features be added:



(h-1) The breakdown of the local connection should remain under the control of the toll operator, so that the toll operator may prepare the complete toll connection and open the local cord only when she is ready.

(h-2) During the waiting time, a guard signal should be displayed, which reminds the toll operator that she has a connection under preparation.

(h-3) The local operator must be notified in case of a toll breakdown; preferably by means of a flashing supervisory lamp signal on the particular cord which was cut off so that the

It is, of course, understood that this operating condition must apply either to toll boards equipped with subscribers' multiple jacks and also to toll boards, where the subscribers' lines may be reached over toll switching trunks.

The circuits arranged for automatic breakdown of local connections for toll calls, may be, of course, used without further change for the operating method of "offered" toll calls. In this case a special additional cord is needed—arranged so that the insertion of the particular plug into the locally busy subscribers' line does not change its electrical conditions. If the

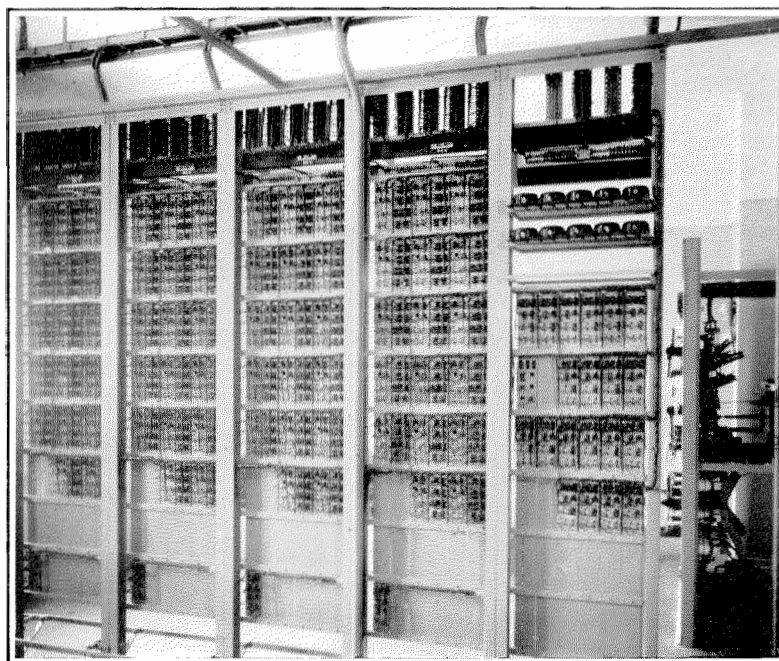

Figure 9—Apparatus Room—Cord circuit relay rack (rear view).

other subscriber (not required for toll) may be informed of the "cut off for toll."

(h-4) The action of cutting off the local cord circuit must, of course, not connect the particular local operator set to the interrupted cord circuit, but the local operator must be able to get in on the connection—either by means of an emergency listening key, if such is provided—or simply by withdrawing the plug, which was just disconnected.

(h-5) The toll operator should be prevented from ringing up by mistake a subscriber who is talking locally.

subscriber accepts the toll call, the special plug is removed, and replaced by the regular toll cord equipped for toll breakdown.

(i) *Subscribers' call metering:* The policy of introducing message rates varies widely; the different countries and subscribers cannot be classified definitely as flat rate or message rate subscribers, because flat rate subscribers, within a short time, may be operated on a message rate basis.

The high efficiency boards of the European type must, therefore, be made suitable for subscribers' message registers even if it is not

necessary to equip them. In the standard manual board, these registers are operated, as a rule, manually. The experience with message registers in automatic exchanges has shown that it is possible to do the metering automatically, with very satisfactory results. There is no good reason why automatic registration could not be introduced in a high efficiency board, especially where such a board is arranged for automatic flashing recall.

Automatic message registration must, of course, be designed to omit the metering of service calls to recording or information desk, and must permit the operator to suppress a call, in case of a wrong number. An alarm signal should be provided to operate in case the register does not meter properly.

(j) *Operator's peg count* (Position meter): Multiple line lamps shorten the answering time, but the full benefit is only secured if all operators cooperate. To this end, a peg count should be provided for every position, as a check for the operators. This meter must be arranged to count automatically either all the connections completed or all calls answered, or both.

Such a peg count for checking the work of the operators must be automatic and beyond interference by the operator. It is not very easy to fulfill this condition for the peg count for answered calls, as this meter is controlled by one supervisory relay only; it is advisable to use or to add a peg count meter for effective (or completed) connections, as this type of meter operates only if both supervisory relays are energized. Such an arrangement offers, in connection with non-interfering answering, a very efficient method for preventing any incorrect manipulation of the meter. As the number of answered calls bears a certain relation to the number of effective calls for every exchange, it is a comparatively simple matter to check, in this way, both peg count figures.

(k) *Party line and coin collector service:*

(k-1) Party line operation is not very popular in Europe, owing to the lack of secrecy, and to the fact that the additional cost involved in correcting this deficiency makes it uneconomical. It is, therefore, entirely satisfactory to omit party line equipment from the standard high efficiency boards and, in every special case where it is required, to adapt the line and cord

circuits to the particular kind of party lines in use.

In connection with the question of party line equipment, there are two points to be kept in mind:

(k-1-1) Owing to the multiple line lamps used in the superservice board, it is not feasible to use one multiple jack lead for every party line station with the usual type of party line sets, and it is, therefore, necessary to provide special ringing keys (common or individual) in the cord circuit, for this service.

(k-1-2) In the standard C.B. board, where a separate answering jack is provided in addition to the multiple jack, the operator's position is arranged for a special "revertive busy test" connected to the third wire of the calling line while the listening key is thrown, so that the operator may hear this special tone when testing, and recognise it as a case of a revertive call. In case of multiple line lamps, the revertive busy test is not needed, because the operator quickly discovers that the number requested is the one she has just answered. On such revertive calls the operator will, therefore, first ask the calling station to hang up the receiver for a short time; she will then remove the answering plug, insert the calling plug and ring the called station by depressing the proper ringing key.

(k-1-3) For the different types of coin collectors, different arrangements in the line or in the cord circuits are necessary, and can be provided in any type of high efficiency board. As, however, the coin collecting service is only a special kind of message rate service, it is understood, of course, that only the automatic flashing recall cord circuits should be used in connection with it.

(l) *Pilot lamps:* As previously explained, pilot lamps in connection with the multiple line lamps are best omitted, but pilot lamps for clearing-out signals are to be recommended. Such lamps were never provided in the standard No. 1 C.B. board, because the additional apparatus required was found to be more considerable than the resultant improvement in service would economically justify.

In the high efficiency board, it is comparatively simple and inexpensive to provide pilots for the supervisory lamps which will light only when

the supervisory signals are displayed, thus reinforcing the clearing out signal and speeding up the disconnection service.

These pilot lamps should be located in the piling rail, together with other alarm lamps needed in the cord circuits, so that the attention of the operator may be solely concentrated on the face of the switchboard, totally disregarding the keyshelf signals, except when removing cord pairs.

#### SUMMARY OF HIGH EFFICIENCY BOARD FEATURES

In the preceding pages, the reason why certain features of the automatic system could, or could not, be applied with advantage to a modern C.B. board has been explained and, furthermore, why certain features peculiar to the manual system were recommended or rejected as unsuitable.

The features accepted are summarized as follows:

(a) *As regards construction.*

(a-1) Sections of the one-position type.

(a-2) Capacity up to about 6,000 lines with no space for answering jacks.

(a-3) No intermediate distributing frame.

(b) *As regards operation.*

(b-1) Multiple line lamps (maximum 5 lamps).

(b-2) No line pilot lamps.

(b-3) Calling line made busy by insertion of answering plug.

(b-4) Operator's bar for both answering and calling cords.

(b-5) Alarm signal in case operator plugs into a busy line.

(b-6) Automatic (keyless) listening (cut in and cut off).

(b-7) "Advance plugging" made impossible.

(b-8) Manual busy test.

(b-9) Automatic (keyless) and clickless ringing.

(b-10) Ringing-back tone to calling subscriber (audible ringing).

(b-11) Automatic disconnection of ringing current on called subscriber answering or on abandoned calls (ringing controlled by calling subscriber).

(b-12) Ringing guard signal during the ringing period.

(b-13) Repeating coil or relay-condenser talking current supply.

(b-14) Absolute secrecy while both subscribers are talking.

(b-15) Two positive clearing out lamps.

(b-16) Clearing out pilot lamps (2).

(b-17) Automatic flashing recall (for answering cords only), with

(b-18) Emergency listening and ringing keys (optional), or with

(b-19) Removal of the calling plug on recall before talking.

(b-20) Recall on calling supervisory lamp without automatic flashing (answered by operating emergency listening key or by withdrawing the answering cord).

(b-21) Automatic disconnecting (line lamp flashing recall) for answering cord only if no subscribers' meters are equipped (optional).

(b-22) Toll operator may break down a local connection at any time (by means of a key).

(b-23) In the interval between plugging into the subscribers' line and breaking the connection, a guard lamp to advise toll operator.

(b-24) The local operator to receive a special preemptory signal in case of a toll breakdown.

(b-25) The local operator to be able to talk to the subscriber in case of a toll breakdown (by means of emergency key or by withdrawing one plug).

(b-26) Toll operator not to be able to ring on a line after breakdown.

(b-27) Automatic subscribers' message registration with discrimination.

(b-28) Operator to be able to suppress metering.

(b-29) Subscribers' meter cuts off the cord circuit only after it has registered.

(b-30) Alarm signal displayed if meter does not register properly.

(b-31) Peg counts for completed (effective) connections, also peg counts for answered calls (optional).

(b-32) Coin collect keys (collecting and returning) (only if required and only in connection with automatic flashing recall circuits).

(b-33) Party line ringing keys (only if required).

Various cord circuits may be developed to satisfy these requirements, the line circuit

remaining practically unchanged (Figure 1). A typical cord circuit (Figure 2), which is working satisfactorily in actual service, will be described briefly in connection with other associated circuits (toll and recording, Figures 3 to 5).

The connecting cords as shown are equipped with emergency listening and ringing keys (*EL* and *ER*), but party line or coin collecting keys are not provided in this case.

The relay condenser talking battery bridge consists of two supervisory relays (*S*<sub>1</sub> and *S*<sub>2</sub>) with two supervisory lamps (*SL*<sub>1</sub> and *SL*<sub>2</sub>).

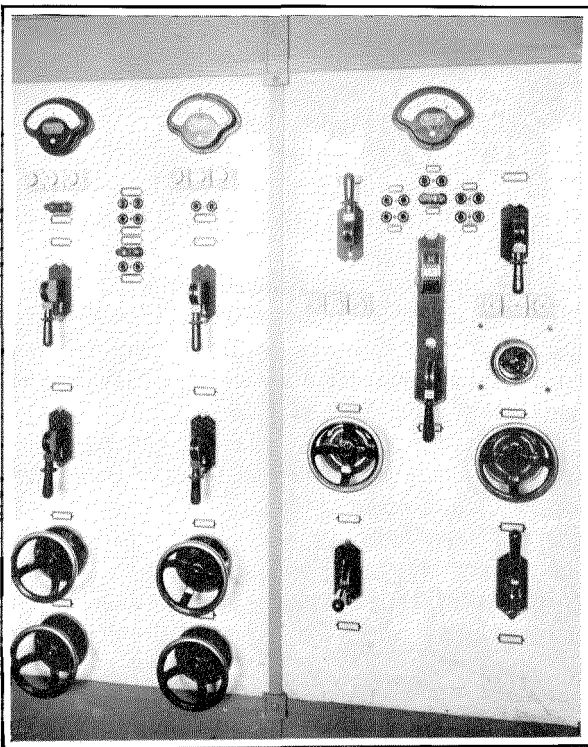

Figure 10—Power Board.

There also are provided: an operator bar relay per cord (*B* and *C*), three relays (*R*<sub>1</sub>, *R*<sub>2</sub> and *R*<sub>3</sub>) for the automatic ringing, one relay *A* for automatic listening, one relay *F* for the automatic flashing recall, two relays (*M*<sub>1</sub> and *M*<sub>2</sub>) for the automatic subscribers' metering and peg count, and one helping out relay *H* (total twelve).

The common equipment consists of a peg count meter *PC* with an associated relay *PR*, of an alarm lamp *ML* with relay *MR* (for out of order subscriber registers), an alarm lamp *FL*

with relay *FP* as operator bar signals, and of two operators lock-out relays *O*<sub>1</sub> and *O*<sub>2</sub> for cutting off the operator's circuit in case she tries to evade the secrecy restriction by using two pairs of cords.

#### OPERATION OF CIRCUITS (FIGURES 1 AND 2)

A detailed description of every step of the operation does not seem necessary, so that it seems sufficient to indicate what relays and lamps operate in any working period. The letter references for such apparatus in general will be included in brackets.

##### (a) Regular local connection

(a-1) Subscriber takes his receiver from hook, *L* operates—*LL* lights (*L.LL*).

(a-2) Operator plugs in (with *P*<sub>1</sub>) and takes order: the marginal relay *B* pulls up (over both windings in series), locks over its low resistance winding, and places in this way a low resistance shunt parallel to its high resistance winding. The *B*. or *C*. relay of any other cord of the switchboard cannot be operated in case its plug is inserted in a multiple jack of the same line.

Relays *CO*, *S*<sub>1</sub> and *A* operate: the operator set is connected automatically to the calling line. But the subscriber meter *SM*, and also relay *O*<sub>1</sub>, do not operate in this case (both being marginal) (*A.B.S*<sub>1</sub>.*CO*).

(a-3) Operator tests a non-busy line (capacity busy test) (*A.B.S*<sub>1</sub>.*CO*).

(a-4) Operator plugs into the called line and automatically connects ringing current to it. Relay *C* energises in a similar way as described for relay *B* "operator's bar." Relay *H* is energised, then relay *R*<sub>2</sub>. "A." relay and the operator's set are disconnected, and the ringing trip relay (*R*<sub>1</sub>) is connected to the calling subscriber line. Interrupted ringing current (exchange battery current during the silent period) is sent over the called line, and a small part of it over a 0.01 *MF* condenser back to the calling subscriber (ring-back signal). During the ringing period the supervisory lamp *SL*<sub>2</sub> lights dimly (over 165 ohms and 35 ohms resistance) as a guard signal (*B.C.S*<sub>1</sub> both *CO.R*<sub>2</sub>.*H.SL*<sub>2</sub>).

(a-5) Called subscriber answers: Relay *R*<sub>1</sub> is adjusted in such a way that it does not pull up with ringing current over the condenser of the

subscriber set. When the subscriber takes his receiver off the hook and closes a direct current path over his transmitter, relay  $R_1$  pulls up (either on ringing current or on direct current during the silent period) and opens the short circuit across relay  $R_3$ . The latter operates, releases  $R_2$  and disconnects  $R_1$  from the subscriber line. The circuit of the supervisory relay  $S_2$  is now closed and operates relay  $M_1$  for a moment (over pilot relay  $P_2$ ) connecting thus the 56 volt meter battery over the common relay  $PR$  and over relay  $M_2$  to the sleeve wire of the calling line. Relay  $PR$  pulls up and closes the circuits of the peg count  $PC$  (which operates once), but the relay  $M_2$  as well as the subscriber's meter do not operate yet, owing to the high resistance of the two windings of relay  $PR$ . It is only after both the peg count and the subscriber's meter have registered, that is, after low resistance shunts are placed across the high resistance windings of the relay  $PR$  and across the meter  $SM$ , that the relay  $M_2$  pulls up and cuts  $M_1$  from the meter battery. Relays  $PR$  and  $M_1$  release, both peg count as well as subscriber's meters are energised, and relay  $M_2$  remains locked ( $B.C.S_1.S_2$  both  $CO.R_3.H.M_2$ ).

(a-6) Both subscribers talk: The operator is not able to listen to the conversation. The throwing of the emergency key  $EL$  remains ineffective ( $B.C.S_1.S_2$  both  $CO.R_3.H.M_2$ ).

(a-7) Both subscribers hang up: Both supervisory relays ( $S_1$  and  $S_2$ ) release, lamps  $SL_1$  and  $SL_2$  light up (clearing out signal), relays  $P_1$  and  $P_2$  operate and pilot lamps ( $PL_1$  and  $PL_2$ ) light up ( $B.C.SL_1.SL_2$  both  $CO.R_3.H.F.P_1.P_2.PL_1$  and  $PL_2$ ).

(a-8) Operator removes cords: All apparatus is deenergised and returns to normal.

(b) *Other local connections (including irregular)*

(b-1) Operator tries to answer a call already answered by another operator. The marginal relay  $B$  does not pull up in this case, but the common relay  $FP$  operates, and  $FL$  lamp flashes so as to give the operator a warning signal. The second operator cannot disturb the existing connection in any way, because the cord used remains disconnected from any cord apparatus. The emergency key  $EL$  when operated does not change the conditions ( $FL.FP$ ).

(b-2) The operator plugs into a busy line

with her calling plug—trying to complete a connection—by mistake or as a result of a simultaneous test. The marginal relay  $C$  does not pull up but relay  $FP$  energises and lamp flashes ( $A.B.S_1.CO.FP.FL$ ).

(b-3) Calling subscriber abandons call during the ringing period (called subscriber does not answer): During the ringing period the following relays are energised and lamps burn:

$B.C.S_1$  both  $CO.R_2.H.SL_2$ .

If the calling subscriber hangs his receiver up, the relay  $S_1$  releases, clearing out lamp  $SL_1$  and the pilot lamp  $PL_1$  light up. Relay  $F$  pulls up, causing relay  $R_3$  to operate, which releases  $R_2$ , disconnecting ringing current from the line. The operation of  $R_3$  puts full potential on the lamp  $SL_2$ , which lights brightly (as does the pilot lamp  $PL_2$ ) so that the operator gets a regular double clearing-out signal, and may disconnect ( $B.C.$  both  $CO.R_3.H.F.SL_1.SL_2.P_1.P_2.PL_1.PL_2$ ).

(b-4) Operator tries to evade secrecy: It was explained under (a-6) that the circuit is arranged in such a way that the operator cannot listen on a talking connection by simply throwing the emergency listening key.

In case the operator tries to get past the secrecy feature by using two pairs of cords, for example connecting by means of two answering cords (after ringing up the called subscriber in the regular way), she will not succeed, because only one of the  $A$  relays operates. The apparatus energised in the first cord circuit is:

$CO.B.S_1.H.SL_2$  (dim.)

and in the second cord circuit:

$CO.B.S_1.A$ .

If the operator should now try to listen by also throwing the emergency listening key (or keys), she will release relay  $H$  of the first cord used, and thus energise the second  $A$  relay. But this now increases the current in the common relay  $O_1$  so that it operates, and energises relay  $O_2$  which in turn connects a buzzer tone to the operator's set.

Apparatus energised in both cord circuits are:  $CO.B.S_1.A$  in addition to the common relays  $O_1$  and  $O_2$ .



(b-5) Calling subscriber flashes his supervisory lamp, after the called subscriber has hung up his receiver (recall).

Before the calling subscriber moves his switchhook, the following apparatus is energised (see *a-6* and *a-7*):

*B.C.S<sub>1</sub>.SL<sub>2</sub> both CO.R<sub>3</sub>H.P<sub>2</sub>.PL<sub>2</sub>.H<sub>2</sub>.*

If the calling subscriber opens his line by depressing the switchhook, the relay *S<sub>1</sub>* releases, *SL<sub>1</sub>* lights (with pilot lamp *PL<sub>1</sub>*) and *F* pulls up and locks over its 1,200 ohm winding. As soon as the calling subscriber closes his line again, relay *S<sub>1</sub>* energises and *SL<sub>1</sub>* lamp starts to flash regularly as does the pilot lamp *PL<sub>1</sub>*. Further movements of the subscriber switchhook do not influence this automatic flashing signal and the operator is now able to talk to the calling subscriber, by throwing key *EL*, which energises relay *A* (over lamp *SL<sub>2</sub>*) and releases relay *F*. The operator may now remove the calling plug (with *EL* thrown), thus causing the release of relays *C.H.R<sub>3</sub>* with *M<sub>2</sub>* and stopping lamp *SL* (with *PL<sub>1</sub>*) from flashing.

In case a second connection is wanted, the operator will test and plug in, and the new connection will be completed as described under (*a-4*) and (*a-5*). If a wrong number is to be corrected and the new connection is not to be charged to the calling subscriber, the operator may prevent the second metering by throwing re-ring key *ER* after the insertion of the calling plug. Such action will put a 35 ohm shunt across the 140 ohm winding of the cutoff relay of the called subscriber line, and will energise relay *M<sub>2</sub>* (marginal) over its 12 ohm winding, thus preventing *M<sub>1</sub>* from operating later when the called subscriber answers.

In case the calling subscriber flashes and wants to re-ring his party—who abandoned the call or hung up by mistake—the operation is the same as just described, but it is, of course, not necessary to remove the calling plug. The operator will simply throw the re-ring key *ER* for a moment, and thus cause the release of relay *R<sub>3</sub>*, energise *R<sub>2</sub>* and place the ringing current on the line again. The meter relay *M<sub>2</sub>* remains locked during this operation, so that a second registration is prevented.

(b-6) If, after the conversation, the calling

subscriber hangs up, but the called subscriber flashes the operator, the lamp *SL<sub>2</sub>* will follow the movements of the switchhook in the same way as in the standard manual board, and the operator may now talk to this subscriber by throwing the *EL* key, as this movement energises relay *A* (over the back contact of the supervisory relay *S<sub>1</sub>*). If the called subscriber wants a new connection, the operator will remove the called plug, insert answering plug and complete the connection as described.

(b-7) If the calling subscriber desires a connection which should not be metered, such as a recording or desk line, the particular line circuit (recording trunk, etc.) must be arranged in such a way that the meter relay *M<sub>2</sub>* energises over the 12 ohm winding (and locks) as soon as the calling plug is inserted, and prevents registering later on when the desk operator answers and the supervisory relay *S<sub>2</sub>* is operated. Such a trunk circuit (Figure 3) must be equipped for this purpose with a low resistance shunt across the 140 ohm cutoff relay, and this shunt must be disconnected only after the *M<sub>2</sub>* relay is energised.

(b-8) Toll operator breaks a local conversation: It is understood that the toll boards used in connection with superservice boards, in the majority of cases are equipped with subscriber multiple jacks because of the comparatively small size of such boards. The toll cord circuit provided for such boards (Figure 6), is, therefore, of the so-called semi-universal type; that is, of a type arranged for connecting a toll line to another toll line or to a C.B. subscribers' line, but not adapted for connecting two C.B. lines together.

In case the toll board is not equipped with subscriber multiple, the toll operator must secure the local subscriber over a separate toll switching trunk ending in a plug before an operator at the local board. It, however, seems sufficient to describe the toll breakdown feature in connection with the semi-universal toll circuits.

The toll cord, as shown in Figure 4, is equipped with the usual ringing, listening and splitting keys, supervisory and clearing-out relays, repeating coil, busy test relay *BTR* and switching relay *UR*, and also with a breakdown key *BK*,

and the *IR*-relay used for the operation of the toll supervisory guard lamp flashing.

(b-8-1) In case the toll operator desires to break the local connection from the answering side of the local cord circuit during the conversation, it will be recalled that relays *B.C.S<sub>1</sub>-S<sub>2</sub>.H.R<sub>3</sub>.M<sub>2</sub>* of the local cord circuit and both *CO* relays of the line circuit are energised during this period.

(b-8-2) The toll operator inserts plug *TP<sub>2</sub>* in the subscriber's jack in question (after testing for busy).

The act of plugging of *TP<sub>2</sub>* operates the busy test relay *BTR* (which cuts off the busy test winding of the operator's induction coil) and the flashing relay *IR*, which flashes the supervisory lamp *SL<sub>2</sub>* and *PL<sub>2</sub>* (guard signal for operator). The marginal relay *UR* does not operate. At the same time, a special tone test is placed on the third wire of the subscriber's line, to make it "toll busy" (*B.C.S<sub>1</sub>-S<sub>2</sub>.H.R<sub>3</sub>.M<sub>2</sub>*, both *CO<sub>2</sub>* - *BTR.IR* and *SL<sub>2</sub>* with *PR<sub>2</sub>* and *PL<sub>2</sub>* flashing).

(b-8-3) The toll operator over the listening key *A* informs the subscriber talking locally that he is required for toll connection, and that his local conversation will be interrupted (at once or later—according to the progress of the toll connection). The condition of the apparatus remains otherwise unchanged.

(b-8-4) The toll operator breaks the local conversation, when she is ready, by operating the breakdown key *BK*. This action places the full 24 V. battery potential on the sleeve wire of the subscriber's line in question; the *B* relay of the local cord is now short-circuited, drops back and releases, and with it the supervisory relay *S<sub>1</sub>*; lamp *SL<sub>1</sub>* lights up as does the pilot lamp *PL<sub>1</sub>*. At the same time, the marginal relay *UR* pulls up and with it relay *SR<sub>2</sub>*, disconnecting lamp *SL<sub>2</sub>* (*C.S<sub>2</sub>.H.R<sub>3</sub>.M<sub>2</sub>.F.SL<sub>1</sub>.P<sub>1</sub>.PL<sub>1</sub>* - *BTR.IR.UR.SR<sub>2</sub>*).

(b-8-5) When the toll operator releases the *BK* key, the marginal relay *UR* remains energised (over the subscriber's cutoff relay) and prevents a new operation of the *B* relay of the local cord circuit just released, because the high winding of the *B* relay is shunted out by the combined resistance of the windings of the relays *UR.IR* and *BTR*. The operation of *UR* disconnects the flashing signal of *SL<sub>2</sub>*, places the talking bridge on the subscriber line and supplies

at the same time battery for the common flashing relay *FP* in the local cord circuit. This relay, therefore, pulls up and closes the circuit of *FL* over an interrupter. This causes lamp *FL* to flash and it gives a peremptory disconnect signal to the local operator (*C.S<sub>2</sub>.H.-R<sub>3</sub>.M<sub>2</sub>.F.SL<sub>1</sub>.P<sub>1</sub>.PL<sub>1</sub>.FP.FL*, both *CO.BTR.IR-UR.SR<sub>2</sub>*).

(b-8-6) In case the second locally connected subscriber, whose party was just taken away for a toll call, did not hang up his receiver promptly as directed by the toll operator, the local operator may talk to him after operating the emergency listening key *EL*, thus again energising relay *A*.

(b-8-7) The toll operator may break down the local connection from the calling side of the local cord circuit, in which case the operation of

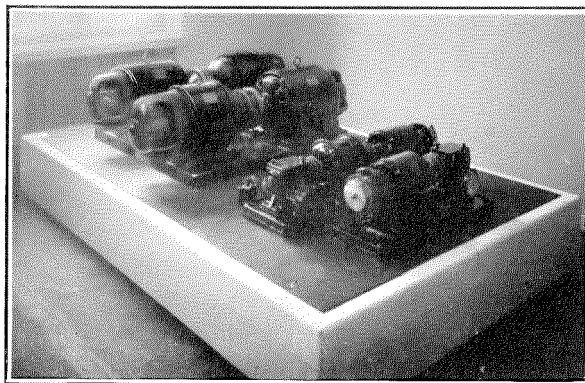

Figure 11—Charging Set and Ringing Machine.

the circuits involved is similar to that just described. She also may break down from either side of the local cord during the answering or during the ringing period with the same result, that is, relay *B* with *S<sub>1</sub>* or relay *C* with *S<sub>2</sub>* are released, lamps *SL<sub>1</sub>* or *SL<sub>2</sub>* light and lamp *FL* flashes.

It has only to be remembered, in case the toll operator requires a subscriber who is just being rung on some local position, that a signal will be displayed on the toll position upon inserting plug *TP<sub>2</sub>* in the multiple jack, because relay *SR<sub>1</sub>* will operate from the ringing current sent from the local cord and lamp *SL<sub>1</sub>* (with *RPL<sub>1</sub>*) will light. The toll operator in this case will not throw the listening key *A*, because she would get ringing current in her receiver, but

will break down the local connection immediately by operating the *BK*-key. The ringing relay of the local cord circuit then will trip over one winding of the *SR*<sub>2</sub> relay of the toll cord and the operation of the circuits thereafter will be the same as described previously.

#### CURRENT CONSUMPTION OF THE HIGH EFFICIENCY CIRCUITS (FIGURES 1 AND 2)

The current consumption of the high efficiency board is far less than might be supposed. It will suffice to make a comparison of the current needed for apparatus operation with that of the standard No. 1 C.B. system, and to disregard for the moment the current necessary for transmission purposes, inasmuch as this current may be assumed to be the same in both systems, even if the transmission bridge, shown in Figure 2, is different from the bridge of the No. 1 C.B. board.

For comparison it furthermore suffices to consider the amount of the signaling current needed during the talking period only, because current flowing before and after the talking period is of short duration and negligible.

In case of the No. 1 C.B. board, there is but the current flowing over the third wire amounting to 0.32 ampere ( $2 \times 0.16$  ampere).

The current flowing during a connection on a high efficiency board of the type shown in Figures 1 and 2 is as follows:

For two sleeve wires:	0.26 ampere ( $2 \times 0.13$ ampere)
For relay <i>H</i> :	0.09 ampere
For relay <i>R</i> <sub>3</sub> :	0.03 ampere
For relay <i>M</i> <sub>2</sub> :	0.04 ampere

or a total of 0.42 ampere, which is only about one-third more than the current consumed in the No. 1 C.B. board.

Adding now an average solid back type transmitter current of the repeating coil type cord circuit of say 0.2 ampere ( $2 \times 0.1$  ampere) to both figures, the total current consumed in the high efficiency board is but 0.62 ampere as compared with 0.52 ampere in the No. 1 C.B. board. This small increase in the cost of power supply affects but very little the total annual operating cost.

#### OPERATORS LOAD ON THE HIGH EFFICIENCY BOARD

The number of busy hour connections which may be handled on the high efficiency board is a very important factor, inasmuch as its economic success depends largely upon this figure.

The operator can certainly answer more calls on such a board than on a standard C.B. board, owing to its labour saving and call distributing features, but the figures found or claimed in actual service vary from 300 to 500 and even 600 calls in the busy hour.

It will be interesting to see what saving in the operator's time may be reasonably expected on a high efficiency board and to determine the operator's time needed for a connection. By comparing this figure with the operator's time and with the basic busy hour load of a No. 1 C.B. board, it is possible to arrive at a fairly accurate busy hour load for the new board.

For the smaller C.B. manual boards, with an average of about ten to fifteen positions, the basic operator busy hour load is generally taken as 230 flat rate calls. For message rate calls this figure is reduced by 5 percent (to 218 calls) if key registering is used.

It is assumed that the operator spends an average of about  $7\frac{1}{2}$  seconds on a connection in the standard C.B. manual board under favourable conditions and "overlapping operations." For European conditions it is safer to consider 8 seconds per connection.

To this must be added the time spent for such irregular service as cannot be considered and charged up as a call; for example, correction of wrong numbers, re-rings, etc., say: 0.5 to 2 seconds according to the different countries, making a total of 8.5 to 10 seconds.

For key metering, the operator's time is increased by 0.5 second or a total time of 9 to 10.5 seconds.

The different features of the high efficiency board save time as follows:

The omission of manual listening and ringing operations saves about 0.5 second, automatic metering for measured service also saves 0.5 second. The total direct saving in the operator's time for a regular connection on a high efficiency board is therefore only 0.5 and 1 second respectively.

The time saving features of the high efficiency boards are more apparent if we consider also the operator's time for irregularities, which consume 0.5 to 2 seconds; most of these irregularities are recalls for re-rings, which are eliminated in the high efficiency board. The additional time required for such calls on this board may be assumed, therefore, at 0.5 second, making the complete operator's time for a flat rate or measured rate connection 8 seconds, as compared with the 8.5 to 10 seconds for a flat rate call and with 9 to 10.5 seconds for a measured rate call on a standard C.B. board.

It only remains now to evaluate the call distributing feature. In the standard C.B. boards the calls appear before the operator in a very irregular way, there being only a small number of lines in a group, and the percentage of the occupied time in the busy hour therefore has to be made comparatively small (50 percent to 60 percent of the busy hour). With 8.5 seconds per call, it is theoretically 54 percent and with 10 seconds it is 64 percent.

But in a call distributing system the traffic is handled in a single large group, the peaks are lowered and operators can be loaded nearer to their physical capacity without increasing the answering time or otherwise affecting the quality of service. For European conditions 80 percent has been shown as entirely feasible and safe in actual service.

If we assume 80 percent, then the operator has 2,880 seconds available per hour for actual work; if we assume 8 seconds per call, we arrive at an average of 360 calls per hour. It should be remembered that this figure holds good for exchanges with an average of ten to fifteen operators; in smaller offices the traffic variations increase proportionally and the figure of 80 percent must be reduced to obtain the same speed of answering. For small groups of four to six operators, a load of 300 calls may be assumed. Ineffective calls (busy calls) are included. This average load of 360 busy hour calls for European high efficiency boards compares fairly well with the generally accepted busy hour load of 450 calls for semi-automatic boards in the same territories.

Let us consider, as an example, an exchange of 4,600-busy hour calls. The No. 1 C.B. board

requires 20 flat rate "A" positions or 21.7 measured rate positions, but the high efficiency board handles this traffic in 12.8 positions and this secures a saving of 36 percent in flat rate and 41 percent saving in measured rate operating wages.

There remains now only the explanation of how it is possible to arrive at busy hour loads of 500 and even 600 calls obtained in actual service. A very efficient operator with the help of an intelligent class of subscribers might reduce the time per call to 6 seconds. Provided that such an operator spends 100 percent of her time on actual work (that is 3,600 seconds), she might be able to complete the above mentioned maximum of 600 connections in the busy hour. Such loads cannot, of course, be taken as a basis for any kind of comparison and should be considered as exceptional; however, they show the great flexibility of the system and its capacity for handling abnormal emergency traffic with safety over a long period.

#### ACTUAL INSTALLATIONS

From among the high efficiency exchanges in service, one has been selected as representative and different views from it are reproduced in Figures 6 to 11 inclusive.

### **3. Simple High Efficiency Boards (C.B. Multiple Line Lamp Board)**

In the preceding pages, different features, which make possible improved service to subscribers and which at the same time facilitate the work of the operators, are outlined. Due consideration is given to the economic aspects of the problem and specimen circuits, which incorporate all the recommended features, are described.

Some telephone organizations, of course, may appreciate the advantages of increased operator's load and the shorter answering time which are possible with the multiple line lamp system, but their requirements may not be such as to justify the adoption of the other high efficiency board refinements which make the cord circuit complicated and expensive. Under such circumstances, the following features may be added to the No. 1 C.B. board:

- (a) Multiple line lamps.
- (b) No pilot lamps.
- (c) Operator's bar for answering cord only.
- (d) Alarm signal in case operator plugs in a busy line.
- (e) Ring-back tone to calling subscriber.
- (f) Ringing pilot signal.

From the operating standpoint, features (a) and (e) are very important. As they entail only very simple and inexpensive additional equipment, circuits fulfilling these requirements need not be much more complicated than circuits of the standard No. 1 C.B. board. In any event, the first cost of such a simple high efficiency board

may be made lower than that of the standard No. 1 C.B. system.

#### **4. No. 11 Switchboard, and Other Developments**

Since the first board of the kind here described was built, other types of high efficiency C.B. boards have been developed, with partly different features and for different classes of service— notably a type now known as the “No. 11” switchboard. Further, to meet the requirements of a special field of service, an alternative type of C.B. high efficiency board, and two types of magneto multiple boards with similar features, have been developed. They will be described in subsequent articles.





# A Theoretical Study of the Articulation and Intelligibility of a Telephone Circuit

By JOHN COLLARD

*European Engineering Department, International Standard Electric Corporation*

**SYNOPSIS:** The paper describes a theoretical study of the quantities that can be used as a measure of the transmission quality of a telephone circuit, and formulæ are developed for determining the relation between the different quantities.

The following practical applications of the theory are discussed and actual examples are given:

(1) Calculation of the relation between various quantities.

(2) Comparison of results taken with different testing techniques.

(3) Comparison of results in different languages.

(4) Determination of a suitable quantity as a criterion of transmission quality.

(5) Development of testing technique for the measurement of various quantities.

## **Introduction**

The recent developments in international telephony have resulted in a movement towards standardisation of telephone circuits and equipment in different countries. In order to promote standardisation, it is essential, in cases where a telephone circuit passes through a number of different countries, that the results of tests and measurements carried out by the different countries on their own sections of the circuit should be capable of correlation. This is particularly so in the case of articulation and intelligibility tests since, owing to the complicated nature of these tests and the differences in testing technique that exist, the conditions existing in the tests of one country will differ from those in another. In fact, attempts to compare articulation results may often lead to errors, due to the differences of conditions existing during the tests. Apart from this, there is the further fundamental difference due to the different languages used in the various countries.

At the present time, therefore, a problem of considerable importance to the telephone engineer is that of determining how results of articulation and intelligibility tests carried out under one set of conditions can be related to tests carried out under different conditions, and how results obtained for one language can be ap-

plied to other languages. A further problem is that of deciding on a suitable unit for the criterion of the transmission quality of a telephone circuit and the development of a suitable technique for determining this quantity. The object of the work described in this paper was to obtain a solution to these problems by studying the theoretical relations between articulation and intelligibility.

## **General Considerations**

The function of a telephone circuit is to convey ideas from one person to another and, hence, a logical measure of the efficiency of the circuit is the percentage number of ideas which are correctly transmitted over the circuit during a conversation. This value, which is known as the *Idea Intelligibility*, the *Sentence Intelligibility*, the *Sentence Articulation* or simply the *Intelligibility* of the circuit, is obtained by calling over the circuit a number of sentences so designed that each one conveys a single intelligible idea. Such a sentence, for example, would be *The man hit the big dog*. The listener records what he thinks he has heard and the percentage number of sentences correctly received is taken as the intelligibility of the circuit.

Since a large number of such sentences must be called over the circuit before a reliable average value of intelligibility is obtained, the method is laborious. To overcome this difficulty another quantity known as the *Syllable Articulation* of the circuit is often used instead of the intelligibility. To measure the syllable articulation of a circuit, a number of random syllables are called over the circuit and the articulation is defined as the percentage number of syllables correctly received. The syllables are sometimes actual words and in this case the articulation is usually called the *Word Articulation* to distinguish it from the *Syllable Articulation* which is obtained with random syllables. It is clear that the value of word articulation for a given circuit will be greater than the value of syllable articulation

because, if the listener knows he is to receive actual words, he can often guess the whole word, even if he does not receive all the component sounds correctly.

There is yet a third value that can be used as a measure of the efficiency of the circuit; this quantity is known as the *Sound Articulation* or *Letter Articulation* of the circuit, and is defined as the percentage number of sounds correctly received when these are called over the circuit in the form of random syllables.

The ordinary subscriber, however, is not concerned with the percentage number of ideas, words, syllables or sounds that can be correctly transmitted over the circuit; these quantities mean nothing to him. What he is concerned with is the relative time required to convey any given piece of information over the circuit. The longer it takes him to complete his conversation, the more he has to pay for the use of the circuit and the greater the amount of his own time that is occupied in making the call.

From the subscriber's point of view, therefore, the efficiency of a telephone circuit should be judged by the relative time required to convey a given number of ideas over the circuit. For this purpose a quantity, called the *Time Efficiency* of the circuit, can be used. This quantity can be defined as the ratio of the time required to transmit a given number of ideas over an ideal circuit to the time required to transmit the same ideas over the given circuit. This quantity will thus have values ranging from zero to unity or, if expressed as a percentage, from zero to 100, the latter figure representing the ideal circuit. This quantity has also been called the *Traffic Efficiency*, but as traffic efficiency is also used to mean the percentage time during which a circuit is being usefully employed, it is suggested that time efficiency is the better expression.

In determining the overall efficiency of a telephone circuit from subscriber to subscriber, or in determining the effects of different factors and conditions on the transmission of a circuit or piece of apparatus, there are thus five quantities that can be used.

(1) *Time efficiency*, defined as the ratio of the time required to convey a given number of ideas over an ideal circuit to the time

required to convey the same ideas over the given circuit.

- (2) *Intelligibility*, defined as the percentage number of ideas correctly transmitted over a circuit.
- (3) *Syllable articulation*, defined as the percentage number of random syllables correctly transmitted.
- (4) *Word articulation*, defined in the same way as syllable articulation, except that the syllables are actual words.
- (5) *Sound articulation*, defined as the percentage number of sounds correctly transmitted.

It is obvious that each of these quantities will depend on the particular technique adopted in making the tests. For instance, different values of articulation would be obtained depending on the number of sounds used to form the test syllables. Similarly, different values of intelligibility would be obtained for different languages.

Further, different results would be obtained for articulation and intelligibility by different sets of observers even when working under identical conditions and using similar testing technique.

With given observers, conditions of circuit and testing technique, a perfectly definite value can be obtained for each of the five quantities defined above. Thus a definite relation must exist between the five quantities, in spite of the fact that a certain amount of apparent guess work enters into the experimental determination of the quantities.

The object of the work described here was to establish, from fundamental principles, the theoretical relations between these various quantities. The equations that have been developed contain a number of constants, and special methods are given for evaluating these. Curves are given showing the results obtained for English, French, German and Italian and examples are given showing the close agreement between calculated and measured values.

The formulæ given here have the following uses:

- (a) They enable the relation between time efficiency, intelligibility and the various forms of articulation to be obtained from theoretical considerations.

- (b) They enable the results of time efficiency, intelligibility and articulation obtained by a certain testing technique to be related to the results of tests carried out under other conditions.
- (c) They enable results obtained in one language to be related to results made in other languages.
- (d) They enable the effect of changes in conditions and testing technique to be studied and so enable a satisfactory technique to be defined.
- (e) They enable the various quantities to be studied from the point of view of their suitability as a criterion of transmission quality and hence allow the most suitable quantity to be chosen.

### *Development of Formulæ*

Before giving the theoretical steps by which the formulæ are obtained, it is necessary to give a short description of the method of making articulation and intelligibility tests.

Before preparing the syllable charts for use in articulation testing in a given language, the language is analysed and a list of the most important constituent sounds is drawn up. By sound is meant a single vowel or consonant. These sounds are then formed at random into groups. These groups may be either monosyllables or multisyllables, but actually single syllables are almost always used. In the following pages the word *syllable* has been used as a general term, including monosyllables and multisyllables, which can be pronounced. In some cases the syllable lists are arranged in such a way that all sounds occur in a list with the same frequency of occurrence. In other cases the frequency of occurrence of the different sounds in the syllable lists is arranged to be the same as that of ordinary speech.

Having drawn up a list of random syllables in this way, the syllables are called over the circuit to be tested and a listener at the other end writes down what he thinks he has received. The listener's list is then compared with the called list and the percentage number of correct sounds or syllables received is determined. In order to avoid any possibility of the listener being able to guess some of the syllables, they are usually arranged so that they are not actual words. This

has the disadvantage that some form of phonetic script is necessary to ensure that the syllables are correctly pronounced and recorded and this requires a special training of the operators. To overcome this trouble some tests have been made in which the syllable charts were prepared in the way already described, except that each syllable was an actual word. They therefore presented no difficulties in pronouncing or recording and special training in phonetic script was unnecessary.

As would be expected, the value of articulation obtained when using actual words is higher than the value obtained when using ordinary syllables, owing to the fact that the listener is often able to guess a word when he has not correctly received all the component sounds.

In making intelligibility tests, a number of sentences are prepared so that each sentence contains a single, intelligible idea. These sentences are then called over the circuit and the percentage number of sentences correctly received is determined. Another method is to call the sentences in the form of a question to which the listener has to reply. The caller then judges from the reply whether the listener has received the question correctly.

### SOUND AND SYLLABLE ARTICULATION

Suppose that, when a series of syllables are called over a circuit,  $D$  sounds out of 100 are correctly received. Then the percentage average sound articulation is  $D$ , and the average probability that a sound will be correctly received will be  $d = \frac{D}{100}$ .

Hence

$$D = 100d.$$

Similarly

$$S = 100s,$$

where  $S$  is the percentage average syllable articulation and  $s$  is the average probability of receiving a syllable correctly. It should be noted that in this paper the discussion deals only with average quantities, so that where, in the following pages, the words, articulation, intelligibility, time efficiency and probability occur, they refer to the average values.

If a syllable consists of one sound only, then clearly the probability of receiving the syllable

correctly is the same as the probability of receiving the sound correctly. Hence

$$s = d.$$

If the syllable contains two sounds, then the probability of receiving the syllable correctly is the probability of receiving both the component sounds correctly. Hence

$$s = d^2.$$

In general, if the syllable contains  $n$  sounds, we have

$$s = d^n$$

or

$$S = 100 \left( \frac{D}{100} \right)^n.$$

Suppose that the lists used for articulation contain  $a$  percent of syllables with one sound,  $b$  percent with two sounds and  $c$  percent with three sounds, then the average probability of receiving a syllable correctly will be

$$s = \frac{1}{100} (ad + bd^2 + cd^3)$$

and, therefore, the syllable articulation will be given in terms of the sound articulation by the expression

$$S = a \left( \frac{D}{100} \right) + b \left( \frac{D}{100} \right)^2 + c \left( \frac{D}{100} \right)^3.$$

For other arrangements of sounds and syllables a similar formula can be obtained.

#### SYLLABLE AND WORD ARTICULATION

When a syllable is called over a circuit, each of the component sounds can be mistaken for a certain number of other sounds, and, since each of the alternatives of a given sound in the syllable can occur with each of the alternatives of all the other sounds in the syllable, there are a large number of syllables for which the correct one can be mistaken.

In general, if the syllable can be mistaken for  $N - 1$  other syllables, i.e., there are  $N$  possible syllables, any one of which may be received when the correct one is called, then the probability of receiving the syllable correctly is  $1/N$ .

We can, therefore, consider the listener as mentally setting out these  $N$  alternatives and choosing one of them.

When the listener knows he is to receive a

syllable which is an actual word, then, obviously, he is able mentally to reject some of the alternative syllables because they are not actual words. He has only a limited number of alternatives, therefore, from which to choose, and the word articulation is consequently higher than the corresponding value of syllable articulation.

Let  $M$  be the number of alternatives that can be received when the listener knows he is to receive an actual word. Then there are  $M - 1$  wrong words for which the correct one can be mistaken. In this case we can consider that the listener sets out the  $N$  possible alternatives, one of which is correct, and then crosses out all the alternatives that are not actual words, being left with  $M$  possible alternatives of which one is correct.

Now the number of incorrect words  $M - 1$  for which the correct one can be mistaken is a certain fraction of the number of incorrect syllables  $N - 1$  for which the correct one can be mistaken.

We can, therefore, put

$$M - 1 = k(N - 1).$$

The value of  $k$  being less than unity and being the proportion of syllables, of any given number of sounds, which are actual words in the language under consideration.

Since

$$k = \frac{M - 1}{N - 1}$$

we have

$$M = 1 + k(N - 1).$$

If  $w$  is the probability of receiving the word correctly and  $W$  is the percentage word articulation, we have

$$\begin{aligned} W = 100w &= \frac{100}{M} \\ &= \frac{100}{1 + k(N - 1)}. \end{aligned}$$

But

$$\frac{1}{N} = s = \frac{S}{100}.$$

Hence

$$W = \frac{100}{1 + k \left( \frac{100}{S} - 1 \right)}.$$

This expression thus enables the relation between the word articulation and syllable articulation to be determined if the value of  $k$  is known.

## ARTICULATION AND INTELLIGIBILITY

In making intelligibility tests, sentences, each conveying a single intelligible idea, are called over the circuit. Now it is clear that some words in a sentence play a greater part in conveying the idea than the others. Consider the sentence *The man hit the big dog*. Here, practically the whole idea is carried by the words *man*, *hit*, *big* and *dog*, so that, even if only these words were received correctly, the correct idea would be received. These words may therefore be considered as the key words of the sentence since they convey practically the whole of the idea. In general, therefore, in determining the relation between intelligibility and articulation, it is only necessary to consider the effect of the key words of a sentence.

Assume that, on the average, a sentence will require  $m$  key words in order to convey an intelligible idea, and let the average articulation of these key words be  $V$ . Then, when a word is called there will be, on the average,  $100/V$  alternatives. Now each of the  $m$  key words will have  $100/V$  alternatives, so that the total number of possible arrangements of  $m$  key words that may be received when the given sentence is called will be  $(100/V)^m$ .

Suppose that the listener was receiving merely arrangements of  $m$  key words, i.e., the words did not necessarily convey an intelligible idea. Then he would have to select mentally one of the  $(100/V)^m$  possible arrangements. He could thus mistake the correct arrangement for  $(100/V)^m - 1$  wrong arrangements.

Now, suppose that the listener knows that the arrangement of key words that he is to receive will convey an intelligible idea. Then he will be able mentally to reject a large number of the  $(100/V)^m - 1$  arrangements because they do not convey intelligible ideas.

He will, therefore, be left with a certain number of arrangements  $h\{(100/V)^m - 1\}$  for which he can mistake the correct one.

The probability of his receiving the sentence correctly is, therefore,

$$\frac{1}{1 + h \left\{ \left( \frac{100}{V} \right)^m - 1 \right\}}.$$

Hence the percentage intelligibility  $I$  will be

given by the expression

$$I = \frac{100}{1 + h \left\{ \left( \frac{100}{V} \right)^m - 1 \right\}}.$$

This gives the intelligibility in terms of the average key word articulation  $V$ .

In the previous paragraph, under *Syllable and Word Articulation*, it was shown that the relation between word and syllable articulation was given by the expression

$$W = \frac{100}{1 + k \left( \frac{100}{S} - 1 \right)}$$

and under *Sound and Syllable Articulation* it was shown that the relation between sound and syllable articulation was

$$S = 100 \left\{ \frac{D}{100} \right\}^n.$$

Combining these two expressions we have for the general case of words with  $n$  sounds

$$W_n = \frac{100}{1 + k_n \left\{ \left( \frac{100}{D} \right)^n - 1 \right\}},$$

where  $D$  is the ideal sound articulation.

The average key word articulation is then given in terms of the word articulation by the expression

$$V = \frac{1}{100} \sum p_n W_n,$$

where  $p_n$  is the percentage frequency of occurrence of words containing  $n$  sounds in ordinary speech.

The intelligibility is therefore given in terms of the ideal sound articulation by the expressions

$$I = \frac{100}{I + h \left\{ \left( \frac{100}{V} \right)^m - 1 \right\}}$$

$$V = \frac{1}{100} \sum p_n W_n$$

$$W_n = \frac{100}{I + k_n \left\{ \left( \frac{100}{D} \right)^n - 1 \right\}}.$$

The value of sound articulation  $D$ , on which these formulæ are based, is the ideal value, i.e., the value that would be obtained on the assump-



tion of ideal pronunciation by the caller. The corresponding value of intelligibility is, therefore, called the ideal value. In the case of actual speech the value of sound articulation obtained falls short of the ideal value. If, therefore, we denote the actual sound articulation for syllables of  $n$  sounds by  $D_n$ , the actual value of intelligibility will be given in terms of the actual sound articulation by the expressions

$$I = \frac{100}{1 + h \left\{ \left( \frac{100}{V} \right)^m - 1 \right\}}$$

$$V = \frac{1}{100} \Sigma p_n W_n.$$

$$W_n = \frac{100}{1 + k_n \left\{ \left( \frac{100}{D_n} \right)^n - 1 \right\}}$$

This question of ideal and actual sound articulation is discussed more fully later under *Average Sound Articulation*.

#### INTELLIGIBILITY AND TIME EFFICIENCY

The time efficiency was defined as the time required to call a given number of ideas over an ideal circuit to the time required to call the same ideas over the given circuit.

Assume that a time of  $t$  seconds is required to call an idea. Then, if  $A$  ideas are called over a circuit which gives an intelligibility of  $I\%$ , only  $AI/100$  of these ideas will be correctly received and the remaining  $A\{1 - I/100\}$  ideas will have to be called again. After calling these again there will still be  $A\{1 - I/100\}^2$  ideas which are not correctly received and must therefore be called a third time. If this is continued, then the total time required to call the  $A$  ideas will be given by the expression:

$$t' = At \left\{ 1 + \left( 1 - \frac{I}{100} \right) + \left( 1 - \frac{I}{100} \right)^2 + \dots \right\} = \frac{100 At}{I}.$$

Now if  $I'$  is the value of intelligibility obtained by the caller and listener over the ideal circuit and  $I$  is the value obtained over the given circuit, the time efficiency for this caller and listener will be

$$T = \frac{\frac{100 At}{I'}}{\frac{100 At}{I}} = \frac{I}{I'}.$$

Hence the time efficiency is numerically equal to the ratio of the intelligibility of the given circuit to the intelligibility of an ideal circuit. The intelligibility obtained by given observers over an ideal circuit is not 100%, of course, because, as pointed out under the heading *Average Sound Articulation* the average sound articulation may be less than 100% for an ordinary speaker. The intelligibility obtained over the ideal circuit will, however, be very nearly 100%, so that the time efficiency for a given circuit has very nearly the same value as the intelligibility for that circuit.

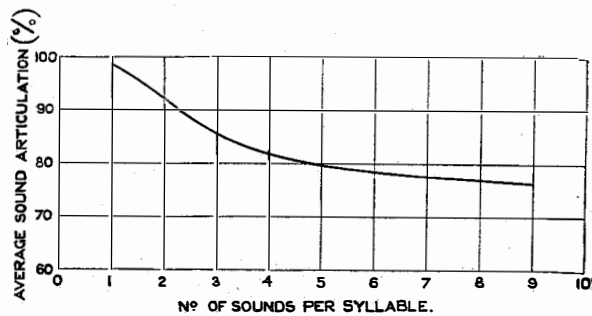

Figure 1.

If perfect observers are assumed so that their value of intelligibility over the ideal circuit is actually 100%, their value of time efficiency for any given circuit will be exactly equal to the intelligibility. In other words, what may be called the *Ideal Time Efficiency* of a circuit is equal to its *Ideal Intelligibility*.

#### AVERAGE SOUND ARTICULATION

The intelligibility was given above in terms of  $D_n$ , the average sound articulation for syllables of  $n$  sounds. This quantity  $D_n$  requires some explanation. If a number of syllable lists are prepared, one list being composed entirely of syllables having two sounds, another being composed entirely of syllables having three sounds and so on, and these are called over an ideal circuit in the same way as the words in ordinary speech, then it will be found that the average sound articulation for a list depends on the number of sounds in the syllables of the list. A curve illustrating the results obtained in this way is shown in Fig. 1. This curve shows that the greater the number of sounds in the syllable, the smaller the value of average sound articulation obtained. This is due partly to the fact

that the caller tends to slur over some of the sounds when the syllable contains a large number of sounds, and partly to the fact that the listener tends to become confused when he receives syllables containing a large number of sounds. This fact only occurs, of course, when the caller is pronouncing the syllables at natural speed and with a natural intonation as used in speech; it would naturally be possible to obtain as good a value of articulation for the long syllables as for the short ones if the caller were to speak very slowly and were to pronounce the sounds with unusual care.

This effect has been taken into account in calculating the intelligibility curve given in Fig. 4.

The value of average sound articulation for any given syllable list will also depend on the proportion of the different sounds in the list. If the different sounds all have the same frequency of occurrence, one value of average sound articulation will be obtained while, if the sounds occur in the list with the same frequency as in speech, a different value of average sound articulation will be obtained. For this reason it is always desirable to state, when quoting a value of sound articulation, how the various sounds were weighted in the test lists.

In this connection it is of interest to study the following figures which give the estimated values of sound articulation for English, French, German and Italian, both for equal weighting and speech weighting, for two particular sets of circuit conditions

Language	Average Sound Articulation			
	Circuit A		Circuit B	
	Weighting		Weighting	
	Equal	Speech	Equal	Speech
English . . . . .	72.3	75.3	54.0	56.9
French . . . . .	71.6	72.4	54.2	58.1
German . . . . .	71.2	74.2	55.5	56.4
Italian . . . . .	72.9	73.4	57.6	59.1
Mean . . . . .	72.0	73.8	55.3	57.6

These figures show that the corresponding values of sound articulation for the different languages are approximately the same, both for the equal weighting and for the speech weighting.

Results of sound articulation in different languages can therefore be compared directly with small error.

Since different callers vary in their pronunciation and different listeners vary in their ability to interpret correctly the sounds they receive, the value of average sound articulation obtained for a given circuit will be different for different testers.

In order to take this effect into account, we can consider the sound articulation  $D$  obtained over any given circuit as being the product of two factors, i.e.

$$D = D_e \times D_i.$$

Here  $D_e$  is the factor just discussed which is independent of the properties of the circuit and which is a measure of the average enunciation of a speaker. It is the sound articulation that would be obtained over an ideal circuit and may be termed the *Average Sound Enunciation*.

The factor  $D_i$  depends entirely on the properties of the circuit, and is the sound articulation that would be obtained over the circuit on the assumption of ideal enunciation. It may, therefore, be called the *Ideal Sound Articulation* of the circuit.

### Determination of Constants

The establishment of these formulæ has necessitated the introduction of a number of somewhat unusual constants and special methods have had to be developed for evaluating these constants. A description of these methods is given below.

#### SOUND AND SYLLABLE ARTICULATION

The formula given above for the relation between the sound and syllable articulation is of the form

$$S = \Sigma a_n \left( \frac{D}{100} \right)^n,$$

where  $a_n$  is a constant which expresses the percentage number of syllables that have  $n$  sounds.

The value of  $a_n$  has therefore to be determined for all values of  $n$  occurring in the syllables used for the articulation tests. This can easily be done for any given set of tests by analysing the syllables that are used and determining what percentage of them contain one sound, two sounds and so on up to the maximum value of  $n$  used in the tests.

## SYLLABLE AND WORD ARTICULATION

The expression giving the relation between word and syllable articulation is

$$W = \frac{100}{1 + k \left( \frac{100}{S} - 1 \right)},$$

where  $k$  is a constant whose value is the ratio of the number of syllable arrangements that are actual words to the total possible number of such arrangements.

The value of  $k$  will depend, of course, on the nature of the syllable arrangements under consideration; the value for two syllable arrangements, for instance, will be different from that for single syllable arrangements. The method developed for determining this constant was to write on a series of cards the different sounds occurring in the language under consideration. Each card had one sound on it but several cards carried the same sound, the number of cards bearing a given sound being proportional to the frequency of occurrence of that sound in the language.

The cards bearing consonants were then all mixed up together and placed in a box, while the vowels were also mixed up together and placed in another box. Now suppose that single syllables are being dealt with; these can be of various forms, for instance, consonant-vowel-consonant or vowel-consonant-consonant. The different forms that can occur and their frequency of occurrence are found from an examination of the language. Suppose that single syllables of the form consonant-vowel-consonant are being considered. A card was drawn from the consonant box, then one from the vowel box and finally one from the consonant box again. These three cards were placed side by side on the table in the order in which they were drawn and the sounds on them therefore formed a syllable of the desired form. This was examined and a note was made as to whether it was an actual word or not. The three cards were then put on one side and the procedure was repeated with other cards from the boxes.

After this has been done a large number of times, it will be found that a certain percentage of the syllables formed are actual words. This percentage is the value of  $k$  for the particular type of syllable investigated. In order to obtain

an average value of all forms of, say, single syllables it is necessary to determine  $k$  for the different arrangements of consonants and vowels and then multiply each value of  $k$  by the frequency of occurrence of the corresponding arrangement in the language.

## ARTICULATION AND INTELLIGIBILITY

The relation between the average sound articulation and intelligibility involves the following constants,  $m$ ,  $h$ ,  $p_n$  and  $k_n$ .

The constant  $m$  is the average number of key words required to convey a single intelligible idea. The value of  $m$  can be obtained by analysing sentences which can be considered to convey an intelligible idea and determining how many key words each contains. If special test sentences are used in measuring the value of intelligibility, then  $m$  should, of course, be obtained by analysis of these test sentences.

Having found a value for  $m$ , the value of  $h$  can be determined. The constant  $h$  is the ratio of the number of arrangements of  $m$  key words which can be said to convey an intelligible idea to the total possible number of such arrangements. The method used to determine the value of  $h$  was to choose  $m$  key words at random and arrange them in random order. These were then inspected to determine whether they could be said to convey an intelligible idea and the number of arrangements satisfying this condition, expressed as a percentage of the total number of arrangements tried, was taken as the value of  $h$ .

The value of the constant  $k_n$  has next to be determined for different values of  $n$ . The procedure to be adopted varies somewhat according to the language to be investigated, and it is not possible in a short paper of this nature to give in full the procedure for all possible cases. Sufficient information, however, is given here to indicate the lines along which the determination is carried out.

Since  $k_n$  is the ratio of the number of words of  $n$  sounds,  $B_n$ , to the number of possible arrangements of  $n$  sounds,  $A_n$ , it is evaluated by determining the values of  $A_n$  and  $B_n$  separately.

The value of  $B_n$ , the number of possible words of  $n$  sounds in the language, or the number known by the average subscriber, is determined by analysing a suitable dictionary and is a straightforward, though rather laborious, task.

The determination of  $A_n$ , the number of possible arrangements, is much more complicated and it is here that the chief difficulty occurs.

Consider, first, the case of a language consisting of words which are formed entirely at random so that there are no prefixes or suffixes common to a number of words. In this case the determination of  $B_n$  would be comparatively simple. Take the case of words having five sounds. Then, if a consonant is denoted by  $C$  and a vowel by  $V$ , the following arrangements of five sounds could be obtained:

VVVVV	VCVVC	VVCCC	CCVCV
VVVVC	CVVVC	VCVCC	CCCVV
VVVCV	VVCCV	CVVCC	VCCCC
VVCVV	VCVCV	VCCVC	CVCCC
VCVVV	CVVCV	CVCVC	CCVCC
CVVVV	VCCVV	CCVVC	CCCVC
VVVCC	CVCVV	VCCCV	CCCCV
VVCVC	CCVVV	CVCCV	CCCCC

Now, suppose, for example, that in the language under investigation two or more vowels are never adjacent in a word and that more than two consonants are never adjacent. The following arrangements are thus the only ones that need be considered:

CCVCC	CVCCV	CVCVC	VCVCC
CCVCV	VCCVC	VCVCV	

From an analysis of the language under investigation it is possible to determine how many different consonants and vowels can occur in the different positions. Take the arrangement  $CCVCV$ , for example, and assume that it is found that when two consonants occur together there are, on the average, only 24 different arrangements that are likely to occur. In the same way, assume that it is found when a single vowel occurs in the body of the word it may be any one of 15 possible vowels. Similarly, assume that 22 consonants can occur alone in the body of the word and that 9 vowels can end a word. Then the total number of possible arrangements that could occur of the form  $CCVCV$  will be  $24 \times 15 \times 22 \times 9$ . In a similar way the total possible number of other arrangements of five sounds can be obtained and, hence, the total number of all the possible arrangements of five sounds. This value divided into the total number of possible words of five sounds then gives the value of  $k_5$  for the language in question.

In a similar way the value of  $k_n$  for other values of  $n$  can be obtained.

In the previous discussion it was assumed that no common prefixes or suffixes occurred. When these do occur in a language they require a modification of the procedure to be followed in determining the word articulation. There are two types of terminations and prefixes that occur in practice and, since the effect on the articulation is different, they must be considered separately. The termination of the first type is that which is added to adjectives in certain languages in order to make the adjective agree with the gender of the noun to which it belongs. Another termination of this type is the termination added to verbs to show person and number, or to nouns and adjectives to show case.

The sounds constituting this type of ending can be said to carry little or none of the meaning of the word and, in fact, in a language like English they are almost completely absent.

From the point of view of articulation, therefore, words of this type can be considered as consisting of a root which carries practically the whole of the meaning of the word and an ending which can be neglected.

The word articulation for a word of this type, consisting of  $n$  sounds and having a termination of  $r$  sounds, would be

$$W_n = \frac{100}{1 + k_n \left\{ \left( \frac{100}{D_n} \right)^{n-r} - 1 \right\}}$$

The number of possible arrangements  $A_n$  which forms the denominator of  $k_n$ , would, in this case, be the number of possible arrangements of  $n - r$  sounds.

The second type of termination or prefix is that which, added to the root of the word, modifies its meaning in some way. Examples of this type of ending in English are *able* and *tion* and examples of prefixes in English are *anti* and *un*.

Since prefixes or suffixes of this type do add definitely to the meaning of the root they cannot be neglected as in the case of the first type. It is not permissible, however, to treat the sounds forming these prefixes and suffixes in the same way as the other sounds in the word for the following reasons. When a common suffix or prefix such, for example, as *anti* occurs in a word,

the probability that this group of sounds will be correctly received is very much greater than would be determined by considering it as four separate sounds. In fact, on the average, the termination or prefix appears to be received more as though it were a single sound than as if it were a collection of sounds. A close approximation to the actual measured articulation is therefore obtained by considering a word of  $n$  sounds with a termination of  $r$  sounds as though it consisted of  $n - r + 1$  sounds. The expression for word articulation thus becomes:

$$W_n = \frac{100}{1 + k_n \left\{ \left( \frac{100}{D_n} \right)^{n-r+1} - 1 \right\}}$$

The value of  $A_n$  used to determine  $k_n$  is, in this case, the number of possible arrangements of  $n - r$  sounds.

In any language, words of all these types usually occur. The average value of  $W_n$  is therefore obtained by calculating  $W_n$  for the different types of words, weighting each value by the percentage frequency of occurrence of the corresponding type of word, and taking the mean of these weighted values.

### Comparison of Calculated Results with Measured Results

A number of examples, in which the values of articulation and intelligibility calculated from the formulæ given here have been compared with the corresponding values obtained by actual measurements, are given below in order to show that good agreement is obtained between measured and calculated values.

#### SOUND AND SYLLABLE ARTICULATION

An experimental curve is given in Fig. 2 showing the relation between sound articulation and syllable articulation for the case in which lists of single syllables were used having half the syllables composed of a vowel and a consonant and the other half composed of a vowel and two consonants. In this case the formula giving the syllable articulation in terms of the sound articulation is

$$S = 50 \left\{ \left( \frac{D}{100} \right)^2 + \left( \frac{D}{100} \right)^3 \right\}$$

In Fig. 2 the dotted curve was plotted from

the above expression and the full line curve from the measured results.

It will be seen that the agreement between the two is good, the maximum difference being only a few percent. This small difference is probably due to the fact that when a listener receives a syllable of the form vowel plus consonant he tends to add an additional consonant before the vowel. In the same way for a syllable of the form consonant plus vowel there is a tendency to add a final consonant. These added consonants were counted as errors when estimating the articulation from the test results and would tend therefore to give a lower value of sound articulation than the corresponding calculated value.

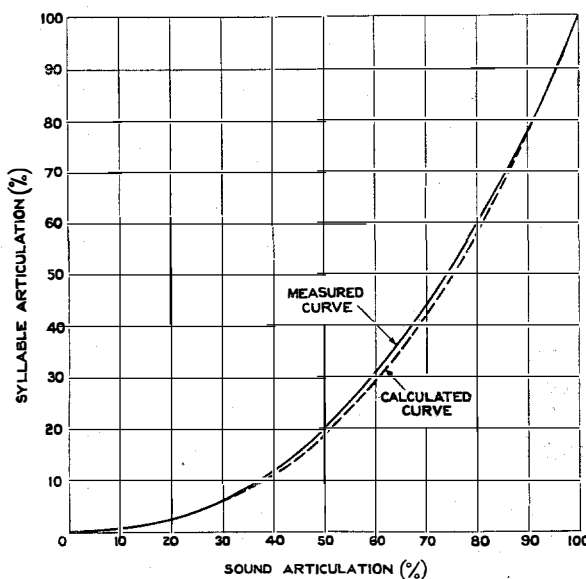

Figure 2.

#### SYLLABLE AND WORD ARTICULATION

In Fig. 3 is given a curve obtained from measured results showing the relation between word articulation and syllable articulation.

The formula for this case is

$$W = \frac{100}{1 + k \left( \frac{100}{S} - 1 \right)}$$

The value of  $k$  was determined for syllables formed of one vowel plus one consonant and for syllables formed of one vowel plus two consonants, and was found to be 0.48 and 0.39, respectively. Since the syllables and words used in



this set of tests consisted half of the form vowel plus consonant and half of the form two consonants plus vowel, the value  $k$  was taken as

$$\frac{0.48 + 0.39}{2} = 0.435.$$

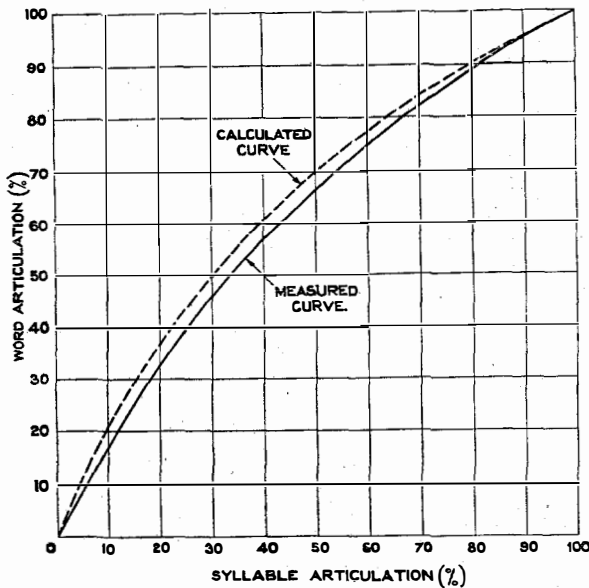

Figure 3.

The curve plotted from this expression is shown by a dotted line in Fig. 3 and the experimental curve is shown by the full line.

The two curves are in good agreement and do not differ by more than a few percent.

#### ARTICULATION AND INTELLIGIBILITY

In Fig. 4 two curves are shown, giving the relation between intelligibility and ideal sound articulation. One of these curves was calculated from the formulæ given in this paper and the other was obtained by actual measurement of intelligibility and sound articulation.

These two curves are in good agreement, showing that the theory gives results which approximate closely to the actual measured values.

As an additional check on the theory, some intelligibility tests were made in English and German under the same conditions.

The ratio of the German intelligibility to the English intelligibility was found to be 1.9, while the corresponding calculated value was 1.7.

These various results show that there are only small differences between the calculated and measured results. The differences that do exist

are only such as would be expected, owing to the difficulty of making accurate intelligibility tests.

#### Practical Application of Theory

This theory was developed primarily to enable results of different articulation and intelligibility tests to be compared, and this is one of its most useful applications. There are, however, a number of other applications which are of sufficient interest to be mentioned here.

Since the theory shows on what factors the articulation or intelligibility of a circuit depends, it enables a suitable testing technique to be developed so that reliable and consistent results can be obtained with the least amount of work.

The theory also enables a study to be made of the different quantities that have been used to measure the transmission quality of a telephone circuit, and so makes it possible to select the most suitable quantity as a criterion.

In addition, it is interesting to make use of the theory to study the relative advantages of different languages from the telephone user's point of view.

These various applications are dealt with in the following paragraphs.

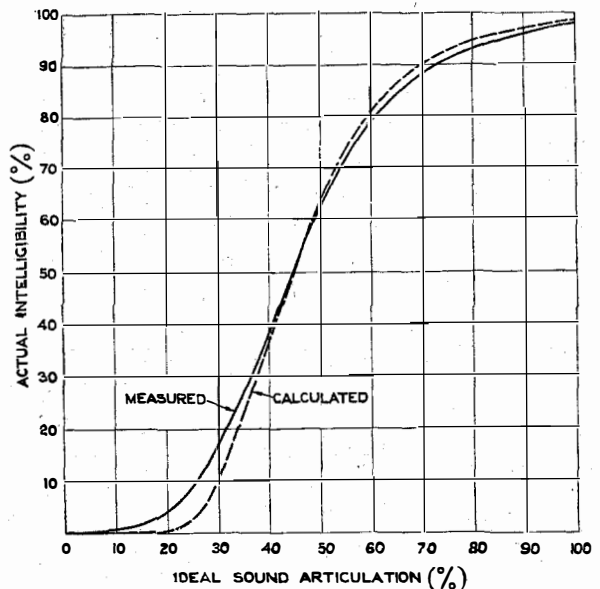

Figure 4.

#### CORRELATION OF RESULTS

During the last few years, several methods of making articulation tests have been published and, as these all differ in certain particulars, the

results cannot be compared directly. As an example of the way in which it is possible to make a correct comparison by means of the theory given here, consider the two following testing techniques.

Technique A is that described by H. Fletcher in the *Journal of the Franklin Institute*, Vol. 193, No. 6, June, 1922.

Technique B is that described by K. Küpfmüller in *Europäischer Fernsprechdienst*, No. 5, July, 1927.

Assume that a value of syllable articulation of 60% is obtained for a given circuit by means of testing technique A which was based on the English language.

In this technique 20% of the test syllables consisted of two sounds and 80% of three sounds. Hence the syllable and sound articulation are related by the expression

$$S = 20 \left( \frac{D}{100} \right)^2 + 80 \left( \frac{D}{100} \right)^3.$$

From this the value of sound articulation corresponding to the syllable articulation of 60% is found to be 83.2%.

In these tests the various sounds had all approximately the same weighting, so that the value of 83.2% is for equally weighted sounds. Now the ratio between sound articulation for equally weighted sounds to the sound articulation for sounds weighted as in speech is approximately constant for all languages and is 0.96. Further, the average sound articulation obtained over a given circuit for sounds weighted as in speech is practically the same whatever language is used. Hence the value of sound articulation for sounds weighted as in German speech may be taken as

$$\frac{83.2}{0.96} = 86.8\%.$$

In the testing technique B, which was based on the German language, 25% of the syllables had two sounds, 51% had three sounds, 21% had four sounds and 3% had five sounds.

Hence the syllable articulation is given in terms of the sound articulation by the expression

$$S = 25 \left( \frac{D}{100} \right)^2 + 51 \left( \frac{D}{100} \right)^3 + 21 \left( \frac{D}{100} \right)^4 + 3 \left( \frac{D}{100} \right)^5$$

and the value of syllable articulation corresponding to the sound articulation of 86.8% is therefore 64.5%.

This shows that a circuit which would give a value of syllable articulation of 60% according to technique A would give a value of 64.5% according to technique B. There is thus a difference between the results given by the two techniques and this example serves to emphasize the need for a standardisation of testing technique. This question is discussed further under the heading *Testing Technique*.

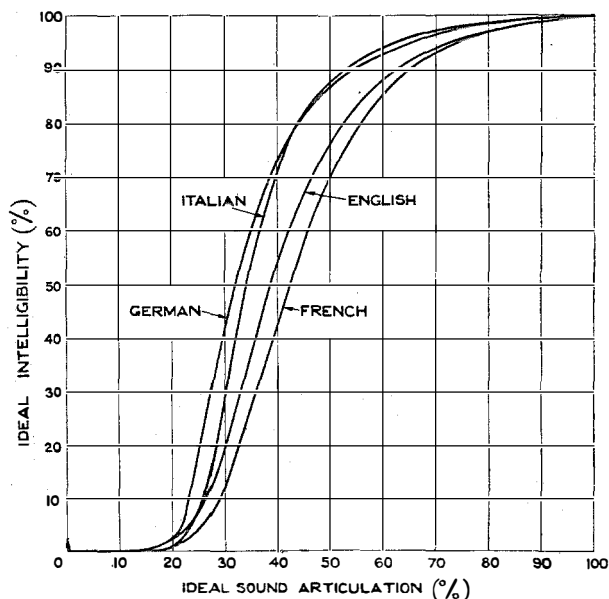

Figure 5.

As a second example of the comparison of results taken under different conditions, assume that a value of ideal intelligibility for French of 80% has been obtained and it is required to determine what the corresponding value would be for Italian. This case is solved directly by means of the curves given in Fig. 5. From these curves it will be seen that the value of 80% for French corresponds to a value of 92.0% for Italian.

As a third example suppose that it is required to find what value of intelligibility in English would be obtained over a circuit giving an ideal sound articulation of 50%. From Fig. 5 it will be seen that the ideal intelligibility for English corresponding to the ideal sound articulation of 50% is 76%, while the actual value of intelli-

gibility calculated for a certain testing crew is obtained from Fig. 4 and is 63%.

#### TESTING TECHNIQUE

It is not proposed to go into the question of testing technique in any great detail, since various publications by different authors have already dealt with this question. There are, however, certain points which the theory shows to be of importance and, since these points do not appear to have received consideration up to the present, they are discussed below.

Since the syllable articulation for a syllable of  $n$  sounds is given in terms of the sound articulation by the expression

$$S = 100 \left( \frac{D}{100} \right)^n$$

it follows that, for a given value of sound articulation, the value of syllable articulation will depend on the number of sounds used in the test syllables.

Hence it is of importance to standardise the number of sounds per syllable that are to be used for forming syllable lists for articulation testing: As an example of the difference that would result in the use of a different number of sounds per syllable, take the case of three observers using, respectively, 2-sound syllables, 3-sound syllables and 4-sound syllables. The values of syllable articulation that these three observers would obtain over a circuit giving a sound articulation of, say, 80% would be, 64%, 51.2% and 41% respectively.

Even if it were decided to use, say, only two- and three-sound syllables it would be necessary to specify the exact percentage of each type of syllable to be used in the lists, since a change in these percentages would alter the value of syllable articulation obtained.

A further effect which should receive attention is that mentioned on page 173 under *Average Sound Articulation* and illustrated in Fig. 1. It was pointed out there that the actual sound articulation obtained depended on the number of sounds in the words or syllables. This effect is most marked, of course, in speech where the pronunciation tends to be less clear than in articulation tests. Experiments have shown, however, that this effect is present even in ordinary articulation tests where the speaker is

articulating carefully, and even with as low a number as two or three sounds per syllable. This is an additional argument for standardising the number of sounds per syllable, and is also an argument for calibrating the operators in terms of some standard reference circuit as suggested in the next section.

Some observers have used syllable lists in which the sounds all had equal weighting, while others have used lists in which the sounds had the same weighting as in speech. The figures given under *Average Sound Articulation* show that there is not much difference between the two values of sound articulation and since, in any case, the ratio between the two values is practically constant, there appears to be little reason for using one value rather than the other.

In the case of intelligibility tests, owing to the much more complicated factors involved, it is even more necessary to standardise the testing technique if consistent results are to be obtained.

The expressions given under the heading *Articulation and Intelligibility* for calculating the intelligibility involve the following factors,  $D_n$ ,  $k_n$ ,  $p_n$ ,  $h$  and  $m$ , and these depend in turn on the following conditions:

- (i) All conditions already discussed for sound articulation.
- (ii) Number of words of different numbers of sounds known by the tester.
- (iii) The number of key words used per sentence.

Since the factors which depend on the knowledge of the testers are so difficult to control, it is doubtful whether any really reliable results would be obtained by making intelligibility tests. It is suggested, therefore, that only values of sound articulation should be measured and that suitable average values of the above constants should be decided upon from a study of the different languages. When a value of intelligibility is required it should be obtained by calculation from a measured value of sound articulation, using the average values of the constants. The value of intelligibility so obtained would then be the average for the given language. This question is dealt with in greater detail in the next section.

### CHOICE OF A QUANTITY FOR THE MEASURE OF TRANSMISSION QUALITY

Five quantities have been defined above, each of which can be used as a measure of the efficiency of a telephone circuit.

These five quantities are:

- (1) Time Efficiency.
- (2) Intelligibility.
- (3) Word Articulation.
- (4) Syllable Articulation.
- (5) Sound Articulation.

It has already been shown that there is a perfectly definite relation between each of these five quantities so that, theoretically, there is no reason why any one of these quantities should be chosen as a measure of circuit efficiency rather than another. From a practical point of view, however, it is desirable to choose the quantity so that, when some change in a given telephone circuit is made, the change in the quantity is directly proportional to the effective change in the transmission quality of the circuit.

As an example of this, take the case of some change in the constants of a telephone circuit which brings about an improvement in the average sound articulation from 75% to 85%. Tests have shown that this change of 10% in average sound articulation corresponds to a change in syllable articulation of 17%, to a change in word articulation of 14%, to a change in intelligibility of 4% and to a change in time efficiency of just under 4%.

The question now is, is the improvement in the circuit, as judged by practical standards, equal to 10%, 17%, 14% or 4%?

The answer to this question is that, since the subscriber naturally judges the circuit on a time or cost basis, the time efficiency gives the true criterion of the improvement in the circuit.

So far it has been tacitly assumed that the subscribers using the circuit are speaking their own language and are fully acquainted with it. In many cases, especially for international circuits, the subscribers are speaking a foreign language with which they are not entirely familiar.

In this case the values of intelligibility and articulation that would be obtained by people speaking a foreign language would obviously be less than those obtained by natives speaking the

language. The question arises, therefore, as to whether the improvement in the circuit from the point of view of a subscriber speaking a foreign language is truly measured by the improvement in the intelligibility of the circuit, assuming this to be measured by natives who are completely familiar with the language.

For this reason it is of considerable interest to consider what modifications in the expressions for the intelligibility of a circuit should be introduced to enable them to be applied to the case of someone speaking a foreign language with which he is not entirely familiar.

The average sound articulation obtained by foreigners for a given circuit will obviously be less than the value obtained by natives, because, in addition to errors due to imperfections of the telephone circuit, there will be errors due to a faulty pronunciation and to the inability of the listener to distinguish clearly between similar sounds.

A further modification is introduced by the fact that the foreigner has only a limited vocabulary.

Consider a listener receiving over a telephone circuit a number of random words of a foreign language. If a given word is one that he knows, then we can consider him as setting out all the possible alternatives to the called word, eliminating those which he thinks are not words and then selecting from what are left the word he thinks is the correct one. Owing to his limited vocabulary, he will reject certain arrangements which are actual words because he does not happen to know them. The results will be that the foreigner is left with fewer words from which to choose than the total possible number from which the native would have to choose. The probability, therefore, of the foreigner getting the word correct, when it is one that he knows, is greater than that of the native. This effect is, of course, modified by the fact that only a limited number of the called words will be known to the foreigner.

The word articulation  $W'_n$  for the foreigner will thus be given by the expression

$$W'_n = \frac{100 q'}{1 + qk_n \left\{ \left( \frac{100}{vD} \right)^n - 1 \right\}}$$

where  $q$  is a factor expressing the fraction of the

total possible words that the foreigner knows,  $q'$  is the fraction of the words he knows in ordinary speech and  $v$  is the ratio of the average sound articulation of the foreigner to that of the native.

As before we shall have the average key word articulation  $V'$  given by the expression

$$V' = \frac{1}{100} \sum p_n W'_n.$$

Also the intelligibility will be given in terms of the average key word articulation by the expression

$$I' = \frac{100}{1 + h \left\{ \left( \frac{100}{V'} \right)^m - 1 \right\}}.$$

It is true that, to be strictly accurate, the expression for the intelligibility should involve factors similar to  $q$  and  $q'$ , used in the expression for the word articulation, since it is conceivable that the foreigner might receive a group of key words which conveyed no intelligible idea to him, although it would to a native. Since, however, cases of this kind would be extremely rare if the foreigner knows enough of the language to attempt to speak it over the telephone at all, the necessary factors would be very nearly unity and can therefore be neglected.

We therefore have the expressions

$$W'_n = \frac{100 q'}{1 + q k_n \left\{ \left( \frac{100}{vD} \right)^n - 1 \right\}},$$

$$V' = \frac{1}{100} \sum p_n W'_n,$$

$$I' = \frac{100}{1 + h \left\{ \left( \frac{100}{V'} \right)^m - 1 \right\}}.$$

Suitable values have been chosen for  $q$ ,  $q'$  and  $v$  for the case of someone whose knowledge of a foreign language is very limited but who just knows enough to speak it on the telephone. This, of course, is the limiting case, and the results have been plotted in Fig. 6, together with the corresponding curve for the native. From these it will be seen that, taking the previous case of an increase in sound articulation from 75% to 85%, an increase of 4% in intelligibility is obtained for the case of the native and an increase of 6.5% in the case of the foreigner. These values of 4% and 6.5% can be considered

as the limiting values so that, for most cases of international circuits, a value in between 6.5 and 4 would be obtained.

The value of intelligibility that the foreigner would obtain over an ideal circuit is seen from the curve to be about 91.5%, since this is the maximum value to which the foreigner's curve tends.

The foreigner's time efficiency can be determined by dividing any given value of intelligibility by the value 91.5.

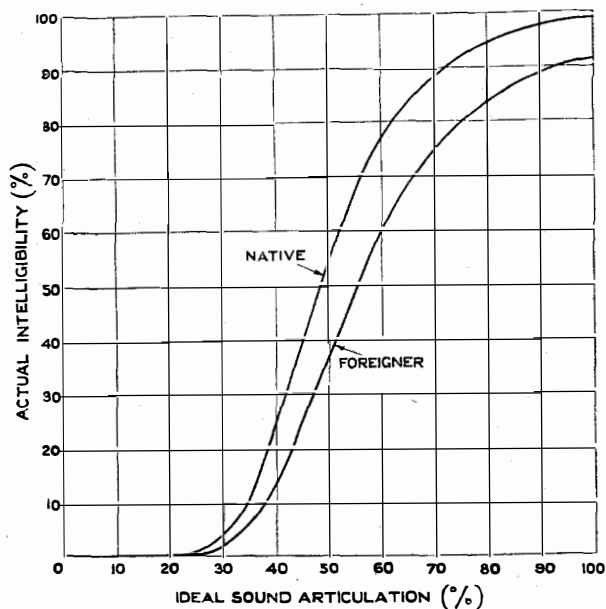

Figure 6.

In this way the increase in the foreigner's time efficiency corresponding to the increase in intelligibility of 6.5 is found to be about 7.1%. This value of 7.1% increase in the foreigner's time efficiency for the circuit corresponds to the native's increase of 4% in time efficiency.

This demonstrates that the improvement of the circuit from the foreigner's point of view is greater than it is from the native's point of view. Hence the time efficiency as obtained for a native is not a true criterion of the circuit from the foreigner's point of view. Since international circuits are often used by subscribers who are not talking their own native language, it is important to consider the effect of changes in circuit and apparatus from the foreigner's point of view as well as the native's point of view.

For this purpose, no one value either of time efficiency, intelligibility or articulation can be

considered as satisfactory. But there is no doubt that the time efficiency, or, what is practically the same, the intelligibility, as obtained for a native, does give a better general idea of the circuit efficiency than the corresponding values of articulation.

As a general criterion of circuit performance, therefore, it is suggested that the time efficiency, as obtained for a native, should be used.

There is, however, another aspect of this question, concerning the choice of a suitable measure of circuit efficiency, which leads to rather different results, and that is from the point of view of drawing up specifications, giving guarantees and correlating test results.

For this purpose some quantity which is fundamental, is easily defined, is easily measured, and is independent of testing technique, is essential. Now, as pointed out in the previous section, the intelligibility, and therefore the time efficiency, depend on so many factors which are extremely difficult to control, since they depend on the personal characteristics of the testers. Time efficiency cannot, therefore, be considered as satisfactory from the point of view of guarantees and specifications.

It is therefore suggested that what has been defined in this paper as the *Ideal Sound Articulation* of a circuit should be used. This quantity is defined as the sound articulation that would be obtained over a given circuit on the assumption of ideal testers, both at the calling and listening ends of the circuit. As already shown, this quantity is practically the same for any language, so that results obtained in one country could be directly compared with results of other countries. It is the most fundamental quantity of all since syllable articulation, word articulation, intelligibility and time efficiency are all based on it and calculated from it. Further, the ideal sound articulation is independent of the testing crew since it assumes perfect callers and listeners. It can be obtained in the following way.

On page 174 it was shown that the value of sound articulation measured on a circuit by a given set of observers was related to the ideal sound articulation by the expression

$$D = D_e \times D_i,$$

where  $D$  is the actual average sound articulation obtained by a given testing crew,

$D_i$  is the ideal sound articulation assuming perfect observers,

and  $D_e$  is the average enunciation for the given testing crew.

Suppose that it be required to determine the ideal sound articulation for a certain circuit by means of measurements of articulation carried out by a given testing crew. When this testing crew measures articulation on the given circuit, they obtain the value of sound articulation  $D$ , so that in order to obtain the value of ideal sound articulation  $D_i$  it is necessary to divide  $D$  by the value of  $D_e$ , the average enunciation for the testing crew. Now the average enunciation of the testing crew is defined as the average value of articulation that they would obtain over an ideal circuit. This value can therefore be obtained by calibrating the testing crew by means of a series of articulation tests on the ideal circuit, which we will consider as the standard reference circuit. An alternative would be to dispense with a telephone circuit and to make the calibration test in a sound proof room, free from echoes.

The complete process is, therefore, as follows:

- (i) Calibrate the testing crew on the standard reference circuit and so obtain their average enunciation.
- (ii) Measure, by means of this same testing crew the articulation for the given circuit.
- (iii) Divide the articulation, as measured, by the average enunciation of the testing crew and so obtain the ideal sound articulation for the given circuit.

Once this value of ideal sound articulation has been obtained, the corresponding value of time efficiency can be obtained by applying the formulæ already developed.

This quantity, the ideal sound articulation, thus fulfils all the desired conditions, i.e., it is fundamental, capable of exact definition, reasonably independent of observers and testing technique, is easily measured, can be related to the corresponding value of time efficiency, and results taken in one country are comparable with results taken in other countries.

Since it seems impossible to devise any one quantity which shall satisfy both the condition that it shall be a true criterion of the circuit efficiency and the conditions just set out in con-

nection with guarantees and specifications, it is suggested that two quantities should be used in the following way.

Standardise the ideal sound articulation as the quantity for the purpose of measurements, guarantees and specifications and all other purposes where the quantity need not be a true criterion of the circuit efficiency, and then convert the ideal sound articulation to time efficiency when a true criterion of circuit efficiency is required.

Since the most logical value of time efficiency to use is the value to be obtained for the average subscriber, it is suggested that standard curves should be got out for the different languages giving the relation between ideal sound articulation and time efficiency for the average subscriber. These curves could be calculated once and for all from the formulæ given here after adjusting the various constants to suit the case of the average subscriber.

The procedure to be followed in determining the transmission quality of a given circuit, or the effect on the quality of any change in a given circuit, would then be as follows.

Measure the sound articulation by means of a testing crew whose value of average enunciation has previously been obtained. Calculate the ideal sound articulation from the measured sound articulation and the known value of enunciation for the crew.

Then from the standard curves determine the corresponding value of time efficiency.

COMPARISON OF DIFFERENT LANGUAGES

When a telephone circuit passes between two different countries it is usual to standardise the language of one of the countries as the operating language, and all conversation between the operators in the two countries is then carried out in that language.

For this reason it is of interest to see whether the theory indicates that there is any reason for choosing one language rather than another.

The curves of Fig. 5 show that the ideal intelligibility is different for the four languages. These languages, arranged in order of their intelligibility, are for the higher values of intelligibility, Italian (the highest value), German, English and French.

In general, it can be said that the greater the

average number of sounds in the words of a language, the higher will be the intelligibility. This is because a language composed of short words will have more words which differ by only one or two sounds than in the case of a language with long words. The smaller the number of sounds by which two words differ, the greater the probability of mistaking one word for another.

From the point of view of intelligibility, therefore, Italian or German would be the best language to use, since less repetition would be required in these languages than in the other two.

There is another consideration, however, which must be taken into account in this connection.

If the average time taken to pronounce a sound is  $b$ , then a word of  $n$  sounds will require a time of  $nb$  for pronunciation, and the average time taken to pronounce a word will be  $1/100 \sum pnb$ , where  $p$  is the percentage number of words of  $n$  sounds in speech.

Taking  $b$  as unity in order to simplify the expression, the following values for the expression  $1/100 \sum pnb$  are obtained for the four languages.

Italian . . . . .	3.9
German . . . . .	3.5
English . . . . .	2.8
French . . . . .	2.7

The time efficiency  $T$  is the ratio of the time taken to call a given number of ideas over the ideal circuit to the time taken to call them over a given circuit, and the time taken to call a word is proportional to the number given above. From this it follows that, neglecting the time interval between words which is small, the actual time taken to call a given number of ideas over a circuit will be proportional to the value obtained by dividing the numbers given above by the time efficiency.

Taking the case of a circuit giving an ideal sound articulation of 70%, the following values of time efficiency are obtained from Fig. 5.

Italian . . . . .	97.2%
German . . . . .	96.5%
English . . . . .	94.0%
French . . . . .	93.0%

Dividing the first numbers by the time efficiencies and multiplying by 100, the following values are obtained.



English.....	2.98
French.....	2.90
German.....	3.63
Italian.....	4.01

These figures show that the actual time required to transmit a given number of ideas over a telephone circuit is smallest for French and greatest for Italian. In spite of the better intelligibility obtained for Italian or German, therefore, it is preferable to use a language like French or English. In other words, it is quicker to speak a language of short words and have to repeat some of the sentences due to the low intelligibility, than to speak a language with long words which has a relatively high intelligibility.

### Conclusions

The formulæ developed in this paper from theoretical considerations enable the relation between the sound articulation, syllable articulation, word articulation, intelligibility and time efficiency to be determined for any language, and therefore make it possible to compare values of these quantities which have been obtained under different conditions of testing technique. These formulæ contain certain constants which can be evaluated from a purely theoretical study of the language in question, without necessitating the making of any articulation, intelligibility or other tests.

It has been impossible to give an entirely rigid proof of these formulæ, since they are based on a number of fundamental assumptions as to the psychological processes that take place in the minds of the operators when participating in an articulation or intelligibility test; these assumptions, although reasonable, cannot be justified by any direct proof.

In addition, no account has been taken of factors such as intonation, accent and the duration of vowel sounds.

The agreement between measured and calculated results is so close, however, as to leave no doubt as to the applicability of the theory in those cases where a comparison has been made.

Few results of articulation and intelligibility tests have been published, so that the checks which could be made, especially in the case of intelligibility tests, have of necessity been limited. It is hoped, therefore, that further results of this nature will be made public so that

a more complete check of the theory can be made, together with such extensions and modifications in the theory as may be necessary. In this connection, too much stress cannot be laid on the necessity of giving very full details of the testing technique employed in obtaining any given data, since, without this, the results may be useless or even entirely misleading.

From the study of the various quantities available as a measure of the transmission quality of a telephone circuit, it has been found impossible to choose one single quantity that will fulfil all the desired conditions.

Two quantities have, therefore, been suggested for practical use. These are the ideal sound articulation and the time efficiency.

The ideal sound articulation is chosen because it admits of simple definition and can be easily measured by a testing crew which has been calibrated on a standard reference circuit in the way described in the section headed *Choice of Quantity for the Measure of Transmission Quality*. Guarantees and specifications could therefore be drawn up in terms of this quantity without difficulty.

The time efficiency has been chosen because it is a true criterion of the transmission quality of the circuit. By means of the formulæ given under *Articulation and Intelligibility* and under *Intelligibility and Time Efficiency*, standard curves can be drawn up giving the relation between the ideal sound articulation and the time efficiency for different languages, so that, once a value of ideal sound articulation has been measured, it can at once be related to the time efficiency in order to study the quality of the transmission.

In conclusion, the author would like to thank Miss D. Hauff and Mr. T. B. D. Terroni for assistance in evaluating the many constants involved in the theory.

### Bibliography

- (1) Harvey Fletcher, "The Nature of Speech and its Interpretation," *Journal of the Franklin Institute*, June, 1922.
- (2) L. C. Pocock, "Faithful Reproduction in Radio Telephony," *Inst. of Electrical Engineers Journal* 62, pp. 791-807, September, 1924.
- (3) L. J. Sivian, "Telephone Transmission Reference System," *Electrical Communication* 3, pp. 114-126, October, 1924.

- (4) H. F. Mayer, "Articulation Tests in Telephony Transmission Systems," *Elek. Nachrichten* 4, pp. 184-188, April, 1927.
- (5) F. Lüschen and K. Kiipfmüller, "Design and Standardisation of Coil-Loaded Telephone Trunk Cables," *Europäischer Fernsprehdienst*, April, 1927, and Post Office Electrical Engineer's Journal 20, pp. 207-220, October, 1927.
- (6) B. S. Cohen, "Apparatus Standards of Telephonic Transmission and the Technique of Testing Microphones and Receivers," *Inst. of Electrical Engineers' Journal* 66, pp. 165-189, February, 1928.

## LIST OF SYMBOLS

The following is a list of the principal symbols used in this paper:

- $D$  = Percentage sound articulation.  
 $d$  = Probability of receiving a sound correctly.  
 $S$  = Percentage syllable articulation.  
 $s$  = Probability of receiving a syllable correctly.  
 $W$  = Percentage word articulation.  
 $w$  = Probability of receiving a word correctly.  
 $N$  = Number of possible syllables that can be received when a given syllable is called.  
 $M$  = Number of possible words that can be received when a given word is called.  
 $k = \frac{M - 1}{N - 1}$   
 $V$  = Percentage key word articulation.  
 $m$  = Average number of key words per sentence.
- $h$  = Ratio of the number of arrangements of  $m$  key words, which convey an idea, to the total possible number of such arrangements.  
 $I$  = Percentage idea intelligibility.  
 $k_n$  = Ratio of the number of words of  $n$  sounds to the total number of possible arrangements of  $n$  sounds.  
 $W_n$  = Percentage articulation for words of  $n$  sounds.  
 $p_n$  = Percentage frequency of occurrence of words of  $n$  sounds in speech.  
 $D_n$  = Percentage normal sound articulation for syllables of  $n$  sounds.  
 $t$  = Time required to call a single idea.  
 $A$  = Number of ideas to be conveyed over a telephone circuit.  
 $t'$  = Time required to transmit the  $A$  ideas over the given telephone circuit.  
 $T$  = Percentage time efficiency.  
 $D_e$  = Percentage sound enunciation.  
 $D_i$  = Percentage ideal sound articulation.  
 $r$  = Number of sounds in a prefix or suffix.  
 $q$  = Ratio of number of words known by a foreigner to total number for a language.  
 $q'$  = Ratio of number of words known by a foreigner to total number for speech.  
 $v$  = Ratio of average sound articulation of a foreigner to that of the native.  
 $V'$  = Percentage key word articulation for a foreigner.  
 $I'$  = Percentage idea intelligibility for a foreigner.  
 $W'_n$  = Percentage articulation for words of  $n$  sounds for a foreigner.



# The Bologna Rotary Automatic Exchange

By CARL CHAPPERON

*Technical Director, Standard Elettrica Italiana*

SINCE the passage of the urban telephone services from Government to private control, a change decided on by the Fascist Government and made effective on July 1, 1925, Italy has been making rapid strides towards the improvement of its telephone communications. The five Concessionaire Companies which are now operating the local systems of the country have all more or less done their share toward renewing the telephone installations of the larger cities, with the result that cities with a population of 100,000 and upward all have, or shortly will have, full automatic telephone plants.

The Rotary Automatic System, notwithstanding very keen competition on the part of the various telephone industries of other countries, has gained territory in Italy. To date, three of the five Concessionaire Companies have adopted it for some of their important cities. In Naples, the territory of the fifth Concessionaire Company, a Rotary Automatic exchange has been in operation for several years.

The most important installation undertaken by the Standard Elettrica Italiana, both as regards the number of lines and the features of the service, is that of Bologna. This city dates back beyond the Etruscan or Roman period and is still one of the most important cities in Italy. It possesses a university which was founded in the year 1000 A.D. In honour of its antiquity as a seat of learning, Bologna was selected for the recent International Congress of Mathematics.

Bologna numbers upwards of 200,000 inhabitants. There are only about 4,000 telephone subscribers but with the introduction of the automatic system the Concessionaire Company expects to increase this number and use all of the 6,600 lines of telephone equipment supplied and distributed as follows: Main Exchange, 6,000 lines; Galliera Sub-exchange, 500 lines; Casalecchio Satellite, 100 lines.

The system installed at Bologna represents the latest Rotary Automatic developments and includes the automatic toll switching system,

which is thus introduced into Italy for the first time. The toll exchange was manufactured and installed by the Standard Elettrica Italiana simultaneously with the automatic equipment. The toll exchange is destined to play an important part in the telephone system of the country inasmuch as Bologna is the connecting centre

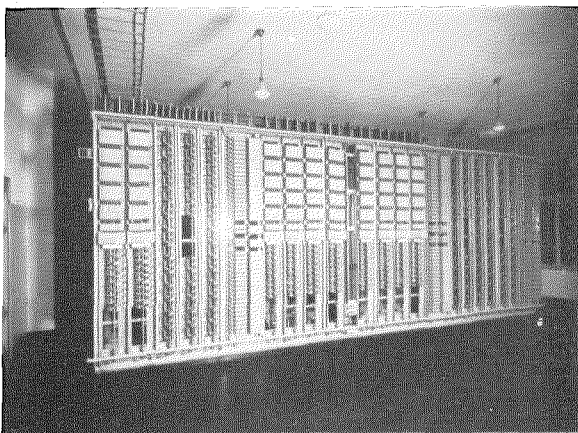

Bologna Central Office Switching Equipment

of the two branches, North and South, of the National Underground Long Distance Cable which is being engineered by the International Standard Electric Corporation and laid by the S.I.R.T.I. (Societa Italiana Reti Telefoniche Interurbane) with the help of the Standard Elettrica Italiana. The toll office, which will serve both the Concessionaire Company's and the State Administration's long distance lines, is composed of 14 sections with 28 operators' positions having 112 toll lines and 120 suburban lines. In addition to arrangements for the application of the pneumatic ticket distributing system, the positions are equipped with calculagraphs and key sets for the direct calling of local subscribers. By means of a special switchboard, called the *Segreteria*, subscribers can book seats at theatres, call for information regarding the arrivals and departures of trains, sporting news, etc. A special taxi-cab call service is also provided.

Bologna was the first city in Italy to be com-



Traces of the Old Roman Road Found at a Depth of 3 Meters from the Level of the Actual Street while Digging a Manhole

pletely supplied by the same Company with all the necessary equipment for the installation of its telephone plant. The Standard Elettrica Italiana, besides having supplied the urban and toll exchanges and the subscribers' sets, also was concerned with the outside plant network which was equipped with apparatus (distributing boxes, protection boxes, junction boxes) manufactured by it and installed under sub-contract by a specialized organization, the STELLA (Societa Telefonica Elettrica Ligure Lombarda Anonima). The laying of the underground cables often presented particular difficulties because of the frequent obstacles which the Company had to surmount, such as the foundations of towers and fortresses built in the medieval era, the walls of which in some points measured ten meters in thickness. Frequently a few meters under the level of the present streets, characteristic blocks of stones comprised in the old Roman roads were encountered.

In order to arrange for the simultaneous transfer, without interruption to the service, of all subscribers from the old manual to the automatic system, ten cables were laid through a 2 m. x 1.50 manhole for providing connections between the old and the new distributing frames and a temporary main frame in parallel with the new automatic exchange was constructed. At the appointed time by means of a single cutting operation the subscribers were passed quickly from the old to the new exchange.

The exchange was inaugurated by His Majesty the King of Italy on June 12, 1928. His Majesty arrived at 3 P.M. at the headquarters of the Concessionaire Company where the exchange is installed, and after having listened to a brief speech of welcome by the President of the Company, proceeded to visit the exchange.

In the room containing the switchracks a ribbon of the national colours was tied between two selector armatures. At one of the extremities of the tape, Eng. Ricci (Technical Director

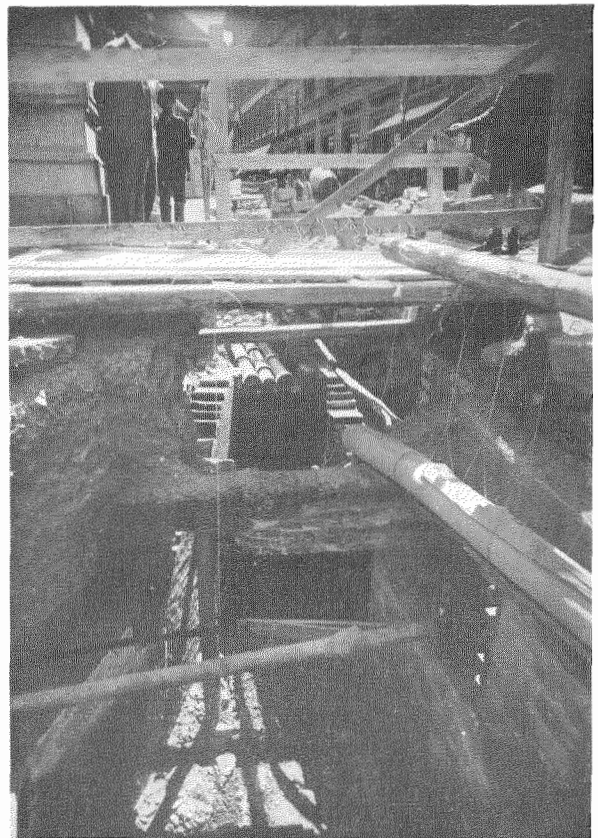

Example of the Underground Complications of the Old City

of the Concessionaire Company) and Messrs. Clayton and Chapperon (Standard Elettrica Italiana) were stationed.

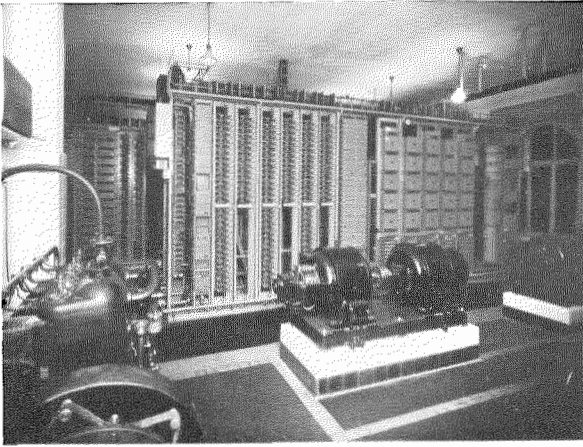

Automatic Exchange and Power Room

An electric button placed behind these three men and within their reach was connected to a bell installed in the power room. When the

tape was cut the signal for current was sent to the power board operator and the equipment was in motion.

When the King entered the hall, followed by representatives of the Government, the President of the Concessionaire Company, Count Isolani, and the Managing Director Hon. Ponti, also Messrs. Clayton, Chapperon and Ricci, were presented to His Majesty. After the work had been blessed by the Cardinal, His Majesty immediately proceeded with the inauguration by the symbolic cutting of the tape. His Majesty was pleasantly surprised and impressed at the immediate operation of the machines and congratulated the representatives of both the Concessionaire Company and the Standard Elettrica Italiana. Since the visit to the exchange lasted approximately 30 minutes, His Majesty and the representatives of the Government accompanying him were enabled to call for explanations with reference to the operation of the equipment.



Toll Office—Telefoni Italia Medio Orientale, Bologna

# International Telephony

By F. GILL

*Vice President, International Telephone and Telegraph Corporation*

IN January, 1923, over 5½ years ago, I spoke before the Post Office Telephone and Telegraph Society of London on, among other things, the urgent need for a new outlook on long distance telephone service in Europe. Since then there has been a very radical change in this service.

Let us begin our historical review by seeing what happened in this service between England

result of this meeting the C.C.I. (Telephones) was formed in 1924; the first President was the late M. Denery, succeeded, on his untimely decease, by another Frenchman, M. Milon. The Secretary-General throughout has been M. Valensi. In assessing the good work which has been done by the C.C.I. this special contribution by France should not be forgotten.

In 1926 service with Germany began. In the

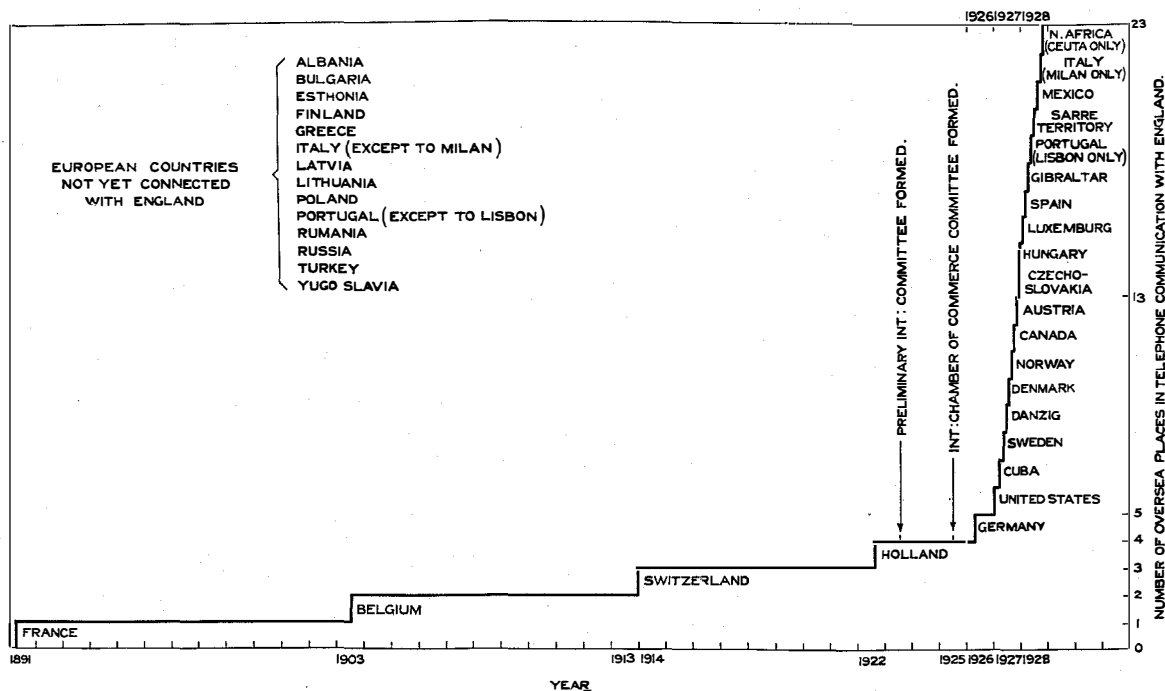

Figure 1—Overseas Telephone Service with England

and other places overseas. Figure 1 begins with service opened with France in 1891; 12 years later in 1903 came service with Belgium; 11 years later in 1914 service with Switzerland began, and in 8 years more (which included the War years), in 1922, came service with Holland.

Then in 1923 the French Telephone Administration took a very momentous step. It called together a Preliminary Committee to consider what should be done to make better provision for dealing with the International service. As a

<sup>1</sup>A paper read before the Post Office Telephone and Telegraph Society of London, October 15, 1928, and reprinted from the *Telegraph and Telephone Journal*.

next year, 1927, 5 services to Europe and 3 to North America <sup>2</sup> were opened, and in the present year, 8 places in Europe, 1 in North America <sup>2</sup> and 1 in Africa, were opened.

We have therefore, between 1891 and 1923, 32 years producing 4 services; since 1923, 5½ years producing 15 services in or through Europe, as well as 4 in North America.

Figure 2 shows the extent of the service between England and the Continent at October 1, 1928.

<sup>2</sup>The American Services were developed apart from the C.C.I.

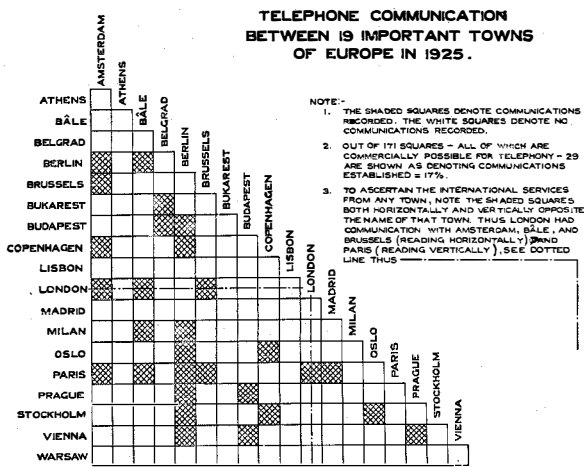

Figure 3

To illustrate to myself and others in a rough and ready fashion the progress taking place, I have been accustomed to consider the service between a number of capital and other cities in Europe, the number of cities being 19. It is obvious that the total number of possible services is  $\frac{19 \times 18}{2} = 171$ . At the end of 1922, before the C.C.I. was formed, there were 28 of these services, equaling 16.4 percent, and of these 28, only 6 involved an intermediate or transit country—all the other 21 were between contiguous countries.

- 1 of these 19 towns had 10 connections.
- 1 " " " " " 6 "
- 4 " " " " " 4 "
- 6 " " " " " 3 "
- 2 " " " " " 2 "
- 2 " " " " " 1 "
- 3 " " " " " No "

By 1925 the number of services to other countries had increased by 1 and was then 29 out of the 171, or 17 percent. (See Figure 3.)

But by May 1928, the work of the C.C.I. had become apparent; the number of these services had grown to 87 out of the 171, or 50.9 percent, and by October 1, 1928, as shown in Figure 4,<sup>3</sup> the number had increased to 98 or 57.3 percent.

A great advance has been made in the degree of transmission given over the International lines; speech which was previously difficult and

<sup>3</sup> These diagrams are the copyright of the International Chamber of Commerce, to whom acknowledgment is made for their reproduction here.

unsatisfactory has, in very many cases, become easy and the improvements continue as from time to time new areas of local territories are admitted to the International System.

Another advance which should be mentioned is the reduction in the time elapsing between the ordering of a call and commencement of conversation. Here are some C.C.I. records of average delays in minutes, during busy hours:

	1925	1927	Last Quarter of 1927, the Latest Record Available
Berlin-Paris . . . . .	130	68	34
Berlin-Vienna . . . . .	143	62	43
Berlin-Stockholm . . . . .	89	39	30
London-Amsterdam . . . . .	61	34	32
London-Brussels . . . . .	31	19	8
Paris-Brussels . . . . .	180	180	100
Paris-Turin . . . . .	180	10	10
Stockholm-Copenhagen . . . . .	8	8	13

But lest it should be thought that all delays are no longer than those shown in the third column, let me say that in the last records there are many cases of average delays in busy hours of 60 minutes and over.

Another advance lies in the changes in service offered, e.g.,

Charging for each minute after 3 minutes instead of by units of 3 minutes.

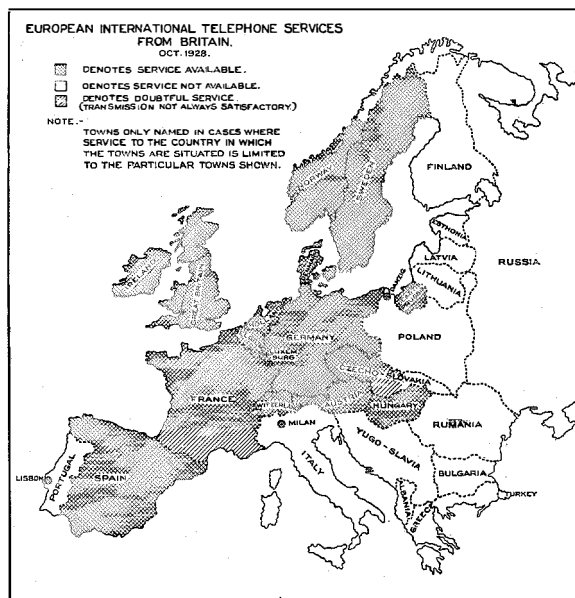

Figure 2



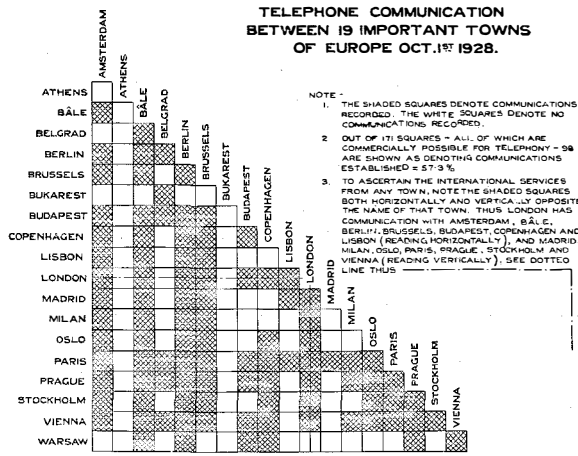

Figure 4

Fixed time and subscription calls made available. "Notice" (préavis) calls have been introduced.

It is sometimes said that Toll Cables and Repeaters were developed during the War and that, of course, the instrumentalities available were very different after the War. Of course, that is true, but it is not the explanation of the lack of service at the beginning of 1923.

For years, overhead bare wires had been the recognized means of transmitting speech; the London-Paris circuit, involving a submarine cable, had been in operation since 1891, 32 years. The New York-Chicago circuit, 1187 kms. long (736 miles), had been in operation since 1892. It is true that it is easier and more economical to give service now with our present facilities, but the real explanation for the lack of long distance service in Europe was the absence of any organization to deal with it.

Thus far we have great encouragement from the relatively rapid advance made recently, and we may well stop for a moment to acknowledge all that the C.C.I. has achieved and to express admiration and gratitude in respect of its work.

But while according our full admiration perhaps we shall do best to leave, for the moment, the things which are behind us and fix attention rather on the things which are in front and remain to be done. We must not forget that all these places are within easy telephonic reach of each other, that they are capital (or equivalent) cities of the countries and that the history has shown that traffic is all the time waiting for facilities.

There still remain, after 5 $\frac{3}{4}$  years, about 42 percent of these cities without connection with each other. There still remain some cities which are very badly served by International connections. Perhaps there will still remain, when all these 19 cities are taken care of, other important cities in Europe not connected, and there will certainly be places just outside Europe still unconnected. Obviously, therefore, it is not yet time for a folding of the hands, nor for contentment with what has been accomplished.

Figure 5 shows a map of 1922; it shows some United States Long Lines then in everyday use projected on the map of Europe. To-day the longest line (practical crow-fly measurement), between International Toll terminating centers in public service is Lisbon to Berlin, about

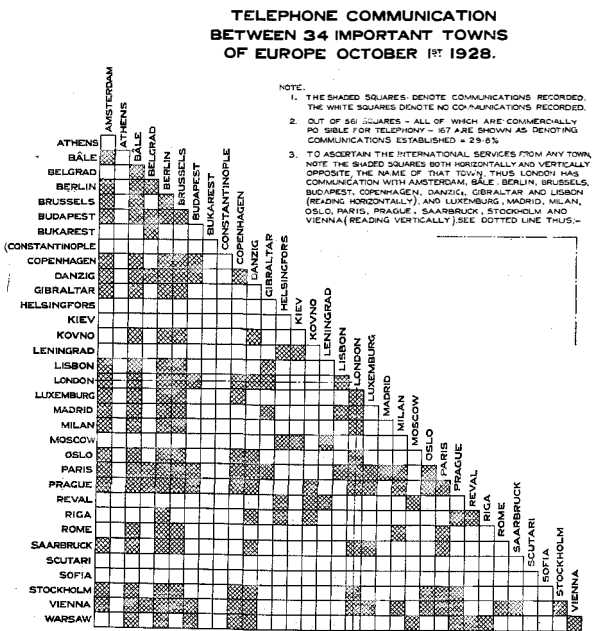

Figure 6

2,310 kms. (1,430 miles). Although this length could be extended by considering the full distance covered between subscriber and subscriber, yet Europe of 1928 is still a long way behind the United States of 1922.

The time has come to extend our 19 cities. Figure 6 gives the list extended to 34 towns; none of these can be dismissed as fantastic. The services which are now in operation, so far as I am aware of them, are shown shaded and

the extent which they are available to the public is 29.8 percent at October 1, 1928.

Towards the extension of service to these places, there were completed in Europe in 1927 5,000 kms. (3,100 miles) of toll cable. The most notable cases were Austria, nearly 800 kms., France over 1,000 kms., Belgium 460 kms. and Germany about 1,000 kms.

### The International Chamber of Commerce

We have spoken of the C.C.I. Telephones; there is another factor which should be mentioned, the International Chamber of Commerce, which first took up the question at Brussels in

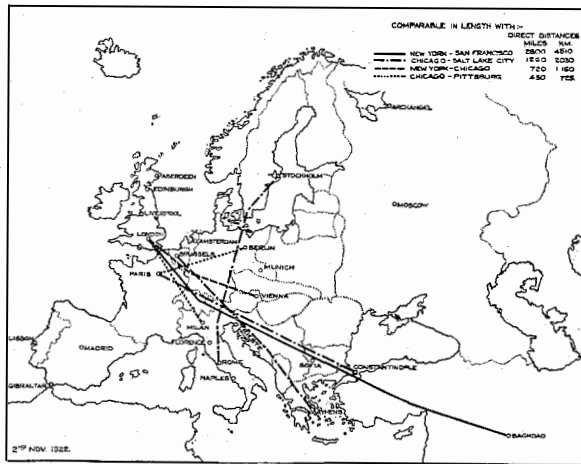

Figure 5—Some United States Long Lines Projected on the Map of Europe

**C.C.I. RATES.**  
FOR DIRECT INTERNATIONAL CIRCUITS  
AT DIFFERENT PERCENTAGES OF ORDINARY AND URGENT CALLS.

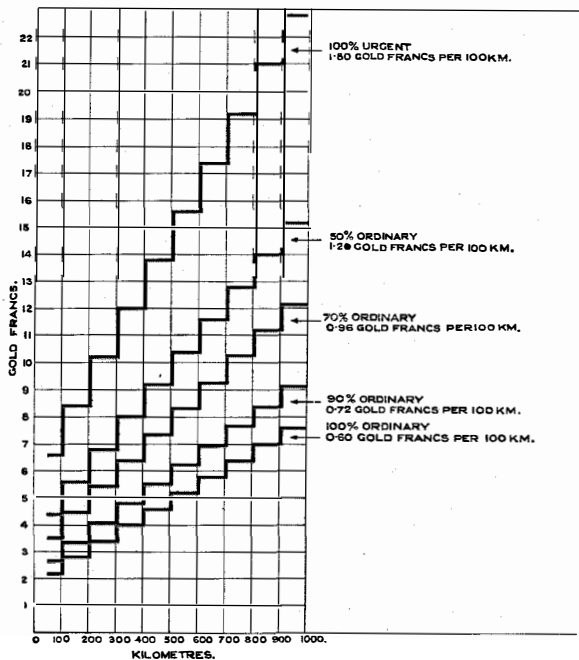

Figure 7

1925 and has throughout operated with the full knowledge of the C.C.I., whose Secretary General attends the meetings of the I.C.C. International Telephone Committee and who has been very good in supplying information. The International Chamber of Commerce has placed on record its ideas of the importance of International Telephony, and the same applies to National service as well. The Report of the Stockholm Congress in 1927 states:

### THE IMPORTANCE OF INTERNATIONAL TELEPHONY

In the consideration of the subject by the Committee they early developed a growing realization of the importance of international telephone service.

(a) As an effective instrumentality for removing impediments to international trade, and

(b) That the ability to secure speedy personal communication between distant cities should be a factor in stabilizing business through a more orderly and economic movement of goods.

(c) That effective telephone service tends to facilitate all the processes of production and distribution.

(d) That ability to communicate information quickly, tends to minimize the range of price fluctuations and thereby lessen the tendency to speculation.

(e) That any instrumentality which tends to stabilize business, facilitate its processes, and effectively extend the field of operations with consequent increase in the volume of trade, should lessen the difficulties of international settlements, as after all, all settlements have to be made ultimately in goods or services.

(f) That the ability to communicate voice-to-voice, easily and speedily, whenever desired or needed, cannot but be a means of improving social relationships and developing a common economic and social viewpoint which inevitably must have an effect in promoting a better understanding between nations.

In the meetings of this Committee it has been particularly noticeable that what the business men desired as expressed in the report presented at the Stockholm Congress in July, 1927, was:

Uniform, dependable, fast service with good audition between all important trading centers in Europe.

Is not that an eminently reasonable request, in keeping with your own ideals? When we couple with that the numerous evidences of rapidly increasing traffic, is it not a worth-while job to follow energetically the development of this Long Distance Service? In the year 1926/27 nearly 37 percent of the small surplus made by the British Telephone System came from the Continental Telephone service, and it seems a fair assumption that this service is a profitable one, as indeed it should be.

Let us now look further to the future and to some of the things which apparently require attention.

### Partial Service

There are still some places which are connected with each other for less than the complete 24 hours of the day. In some other instances

ally experience a delay of not more than 30, 60 or 90 minutes, according to the length of the circuit. Calls may be ordered to be "Urgent" at triple ordinary rates, or to be very fast, "Lightning," at 10 times ordinary rates. Equipment is not intended to be provided to meet busy hour loads, but is to be provided on the basis of the load spread out by reason of the delays permitted. Cheaper rates are in force in times of light traffic.

B. All calls are of equal urgency and pay the same rate, called here the "Day" rates. A fast service with a delay not exceeding, say, 10 minutes, is aimed at. Equipment is provided to meet the busy hour load. Cheaper rates are in force in times of light traffic.

As would be expected, plan A leads to more calls per line per day, longer delays and a cheaper "Ordinary" rate. Plan B leads to fewer calls per line per day, a faster service and a "Day" rate which is dearer than the "Ordinary" rate under plan A.

But, obviously, the "Ordinary" rate may not be the rate paid by an individual, nor yet the average rate; this latter will depend upon the proportions of ordinary, urgent, and lightning calls.

To contrast the "Ordinary" Rates, plan A, with the "Day" Rates, plan B, is obviously misleading, yet it is constantly being done. Take a case of, say, between 700 and 800 kms.; at C.C.I. ordinary rates, the price is 6.4 gold francs. Against this take the London-Zurich day rate, 10.0 gold francs (about the same distance but including a submarine cable). But if we assume that out of 100 calls, 87 are ordinary, 12 are urgent and 1 is lightning, then the average C.C.I. rate would be 8.51 gold francs, leaving 1.49 gold francs for the submarine cable of the London-Zurich circuit.

Or take the case where the ordinary calls are only 34 percent, the rest being at triple rates; the average price for 800 kms. at C.C.I. Rates would then be 14.85 gold francs.

Figure 7 illustrates the C.C.I. Toll Rates as they vary in accordance with the proportion of Urgent calls.

Figure 8 illustrates a published case; over a

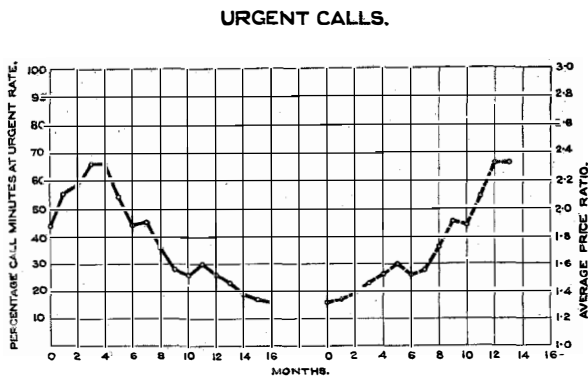

Figure 8

connections are set up every alternate half hour to produce direct trunks, thus producing the effect that there is only connection between A and B during each alternate half hour and between A and C during the other alternate half hours. This produces long delays.

### Toll Rate Principles

There are two entirely different foundations for the toll rates in force in Europe. There is no difference in the degree of transmission afforded, and the two may be stated in condensed form thus:

A. Service is given at as cheap a rate as possible, this rate being termed "Ordinary." Ordinary calls should habitu-

period of 16 months the percentage of call minutes at urgent rate rose from 45 percent to 66 percent and then fell to 16 percent, with a consequential great drop in revenue owing to the heavy falling off in calls bringing in three-fold fees, a loss not compensated for by general increase in toll traffic. The cause of the fall in urgent fees was that more trunks had been added and owing to a faster service, due to these additional facilities, there was less need to pay triple rates.

The right hand part is the same curve reversed. I have assumed it is fair not only to consider what happens when the proportion of urgent

If an urgent call at triple fee matures in *reasonable* time, it would seem unlikely that the speed could be so increased as to make a tenfold fee attractive; or conversely, if the tenfold fee calls are made, is it not rather because the urgent calls are much delayed and the ordinary calls are impossible? There are cases where the urgent calls over the whole day are about 70 percent of the total; probably that means that all the calls in the busy hours are urgent at triple rates. In some cases a lightning call passes out of that category into an urgent call if it does not mature in 15 minutes.

When it is found that the public pays a triple fee to reduce somewhat the average delays, is not that evidence that they are willing to back up your efforts to supply first class service? Here are some figures of these delays:

ZONES.

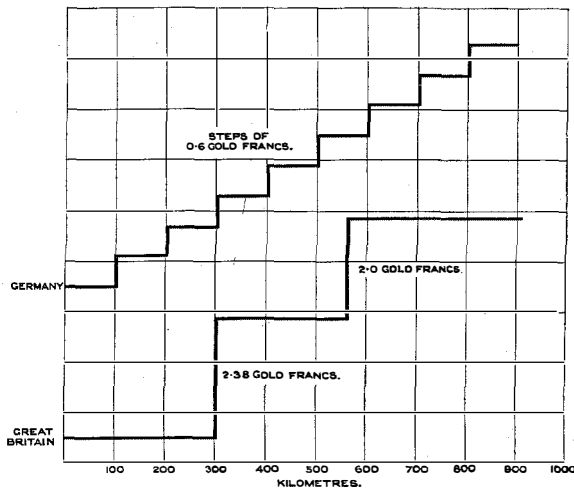

Figure 9

fees falls off, but also when it increases. It increases because of congestion; subscribers making calls and suffering delays endeavor to mitigate their trouble by placing urgent orders. The scale at the right hand shows the average price ratio, assuming no lightning calls; in this assumption the average price ratio increases from 1.32 to 2.32, an increase of 76 percent. Is this likely to give satisfaction to the subscribers? Will they not examine their bills and feel that their calls are costing much more? Then when more trunks are added, as they must be, is not the Telephone Authority in a dilemma? If it improves the speed it may involve (in the case quoted it *did* involve) a loss in total revenue while, at the same time, it increases expenses.

One wonders—Can there be a real place for lightning calls at 10 times the “ordinary” fee?

EXAMPLES OF AVERAGE DELAYS IN MINUTES, ORDINARY AND URGENT, ON THE SAME CIRCUITS IN BUSY HOURS, 1927. C.C.I. RECORDS

On Ordinary Calls	On Urgent Calls	% of Urgent Calls
20.....	8	10.0
13.....	6	2.4
16.....	9	4.5
71.....	41	12.5
18.....	5	1.8
38.....	17	not shown
41.....	28	
33.....	13	
90.....	36	
120.....	48	

All these points rather suggest that these special rates are founded upon old-time inadequate facilities, and will have to be abandoned in modern systems.

It is usual in Europe to consider the Toll Rates in the United States as altogether too high for Europe. But is that so, if we compare like with like, or as near as may be? In the A. T. & T. Report for the year 1927 it was stated:

The average length of time for handling a toll call in the Bell System was reduced from 2 minutes in 1926 to 1½ minutes in 1927. About 90 percent of all toll calls are now handled while the subscriber remains at the telephone, as compared with 80 percent a year ago.

Take a case of a call between places, say, 1,430 kms. (890 miles) apart, and assume as near as may be similar service.

The Bell Long Distance Rate for Person to

Person service would be 23.40 gold francs for a 3-minute call.

The C.C.I. Lightning Rate on direct trunk would be 100 gold francs for a 3-minute call. It is doubtful if the delay would be any less than the delay on the Bell System, and the service would be inferior, in that no Particular Person Service would be afforded and the individuals required would have to be sought after communication was established, which might increase the fee. The reason why no Préavis call is assumed in this case is that with the very fast call there would be no time in which to send the preliminary notice.

The C.C.I. Urgent Rate, with Préavis fee would be 33.30 gold francs for a 3-minute call. The delay would almost certainly be considerably more than in the Bell System call.

But comparing rates in different countries by merely converting the currencies is liable to be misleading, because it takes no account of the *relative* burden which the rate imposes, because that method pays no attention to the wealth of the person paying the rate. If consideration be given to this point, the United States rates are a good deal cheaper than they appear to be.

I submit that all the evidence tends to show that Europe desires a high-speed service, is willing to pay for it and that it should be possible to provide it.

Another matter in toll rates that requires unification is the various methods at present employed in zoning International calls. Figure 9 contrasts the steps which constitute a zone in Great Britain and Germany. Note, that the position of the two curves does not imply any relative price comparison.

### ***Person to Person Service***

Another service facility about which there is at present lack of uniformity is that of Person to Person calls.

Mr. Lignell of the Swedish Administration has shown that in the Swedish experience the demand for this service increases with the length of the circuit. This seems quite what would be expected. If *A* in London wants to talk to Vienna, it is likely that *A* wishes to get into communication with a definite individual, *B*, and it is probably not of much interest to *A* to

talk to *B*'s office or hotel and be informed that *B* is absent. Further, the time lost in calling to the telephone the particular person whom *A* wants is a wasteful and serious inroad on the time paid for.

The Person to Person service gets rid of these objections; both the persons who are to talk are brought together at the moment of starting the time to be paid for, and the operating organization receives an enhanced fee for the additional work it has to do.

At present Europe has in places, not with England, however, a service called Préavis, which is a "sort of" person to person call. But it is not the real thing as you have it on the Transatlantic service.

There is so much unprecise use of the words "subscriber" and "line," that in considering this kind of service it seems well to pose a case and to test any service offered on this case. Assume then, a person *A* from an extension on Holborn 1234 in London wishes to talk with person *B* who will be found on an extension on Carnot 5678 in Paris. The time to be paid for is not to begin until *A* and *B* are in conversation.

The complete préavis service is made up of two calls, a preliminary notice, the Préavis, sent over the trunk and given by the incoming Trunk operator to the wanted number, to the effect that a call will shortly be coming from (in the above case) London, and that *B* will be asked for. If *B* will be ready (and for our present purpose we need not follow other variations), the call proper will mature and be treated very much in the ordinary manner. Thus the préavis is the preliminary notification, it bears a separate fee which is based upon the unit fee, and it is followed by an ordinary call. In actual service the préavis practice differs. Sweden in its connections with Norway and Denmark, puts the names of the two individuals on the ticket and when the call matures the operator gets these two persons into conversation before starting the time to be charged. But other countries do not go so far; they seem content with getting the two P.B.X's. into connection and start the time to be paid for from that moment. In fact, the actual call is an ordinary call with no precautions, except that when each of the two stations or P.B.X's. reply,

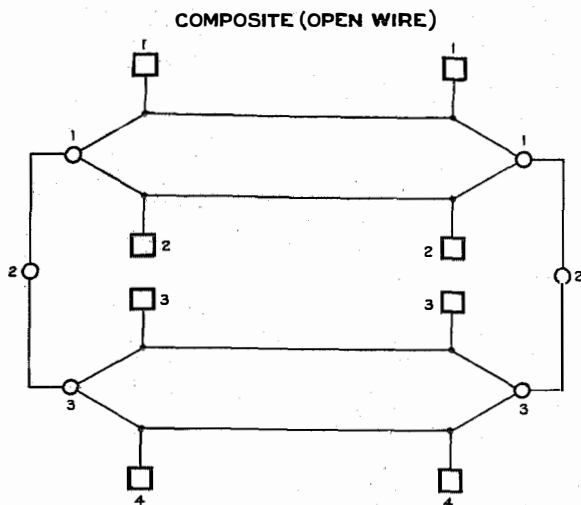

Figure 10

they are given the name of the individual wanted and the name of the distant town.

Substantially, Europe does not at present enjoy a Person to Person service<sup>4</sup> and with the increasing length of International lines this facility seems overdue. In considering the future of this kind of service three statements seem likely to be true:

The longer the connection the greater the demand for Person to Person service.

The greater the Person to Person service the greater the demand for speedy service.

The more speedy the service the greater the likelihood of the *préavis* type of call being abandoned.

### Unused Facilities

If we consider 4 wires giving telephone service on 2 channels, by means of suitable terminal arrangements and by proper transposition of the wires, we can make a third circuit without adding any more line wire, and the longer the line and the heavier the wires the more desirable economically does this third circuit become. In nearly all toll cables and on most open wire circuits this creation of a phantom circuit is commonly employed.

But there are other facilities which at present are unused on International lines in Europe,

<sup>4</sup>Since writing the above, I learned that the British Post Office has already made proposals for a real Person to Person service and I hope that its efforts will be successful.

although they offer great attractions. The same 4 wires if of open bare wire construction can, without robbing the telephone income in any way, also provide 4 independent two-way telegraph circuits, while if in cable there may be added two independent two-way telegraph circuits.

Figure 10 shows in circles the 3 telephone rentals collectable from 4 open wires; these are very generally used. It further shows in squares the 4 telegraph revenues which may also be collected from the same wires and these last are practically neglected in Europe.

Figure 11 shows in circles the 3 telephone rentals obtained from 4 cable wires and the two telegraph rentals which are being neglected. The illustration is for 2-wire telephone circuits; the same telegraph revenues are possible if the telephone circuit is a 4-wire one.

Again, on open wires, without detriment to the ordinary telephone rentals, we can, by carrier, add three other conversations simultaneously and thus in many cases increase the income-earning power of a pair of wires from  $1\frac{1}{2}$  to  $4\frac{1}{2}$  and, with the 2 telegraphs, to  $6\frac{1}{2}$  rentals; or on the same pair and without injury to the ordinary telephone rentals, we can add 12 two-way telegraph rentals, 10 being by carrier and two by composite apparatus. Or again, in a telephone toll cable which has spare circuits available, by giving up telephony on one pair, we can provide for 6 two-way telegraph rentals.

Now since all these arrangements are made by apparatus, it is approximately correct to say that their attractiveness increases with the length of the line, and yet surprisingly little use is made of these facilities, even though the number and length of long lines is growing rapidly. The London-Madrid circuit is one of the very few such cases within my knowledge; in this case a pair of open wires between Versailles and Zaragoza, in addition to the ordinary telephone circuit and half a phantom, carries 3 telephone carrier channels with their accompanying rentals, and it could also carry two telegraph composite circuits.

There is another case between Copenhagen and Hamburg where two extra telegraph circuits are provided by composite. I understand also that there are some voice frequency telegraphs

used on International telephone circuits in France.

Now more or less throughout Europe the Telegraph Departments are in financial difficulties, suffering from the competition of the telephone. Is there not in these extra facilities a means of reducing the annual cost of lines; may it not even be economical to cut down existing telegraph lines and use telegraph circuits which can be provided at little extra cost and be utilized either in the public service or leased as private wires at attractive rates? If, for example, at a cost which relatively is low, it is possible to operate 12 two-way telegraph circuits, between say, Paris and Vienna, over a four-wire telephone circuit, is it not possible, by suitably adjusting the rentals charged, to build up a profitable business by the use of these neglected facilities?

Possibly the fact that the long lines of Europe pass through more than one ownership is one reason why, apparently, no one seems to feel the urge to make the most of these long lines. Or it may be that there are difficulties in the fact that frequently there are practically two departments, the telephone and the telegraph, which have to see eye to eye before these facilities can be employed. But it does seem that full use is not being made of the money which has been expended. Perhaps this is a matter on which the C.C.I. (Telegraph) could do good work.

### *The Future of International Telephony in Europe*

Why do we use the expression International Telephone service as if it were something special and different from ordinary Long Distance service? The answer is one of organization. In ordinary Long Distance service, the whole toll circuit and frequently both local ends are in the hands of one administration, responsible for all the arrangements and in a position to take at short notice any action it may judge necessary.

But in the International service a Toll circuit belongs to and is operated by at least two authorities; there may be several more. Each of these authorities has its own sovereign powers, its own way of doing its work, its ideals of

service, technique, hours of duty, costs and manner of charging the public.

A telephone message is not like a parcel or a train, which progresses from moment to moment and does not occupy very much space at any one time. In telephony, the whole circuit is simultaneously and exclusively occupied with the one call and should be so constructed, maintained and operated, that its different sections under different controllers are harmonious and operate as one whole.

I confess that I find it a very difficult thing to imagine this harmonious working carried to a high degree of efficiency under the present system of multi-control. Of course a great deal has been, and undoubtedly in the future will be, done, but there are degrees of efficiency and it certainly seems to me that multi-control can never, with the best will in the world, produce results comparable with those given by unity of control.

The function of the C.C.I. so far, has been to form a common public opinion among the long distance telephone authorities of Europe as to certain matters, such as specifications for the construction of long lines, rules regarding maintenance and some standardization of traffic and rating matters, though these two are not as advanced as what is known as the Transmission Section. But in daily operation of the service much more than common opinion or a book of rules is required. At present no one person is in charge of general policies and decisions; no one is able to lay out new circuits which the traffic requires, nor to make definite programmes

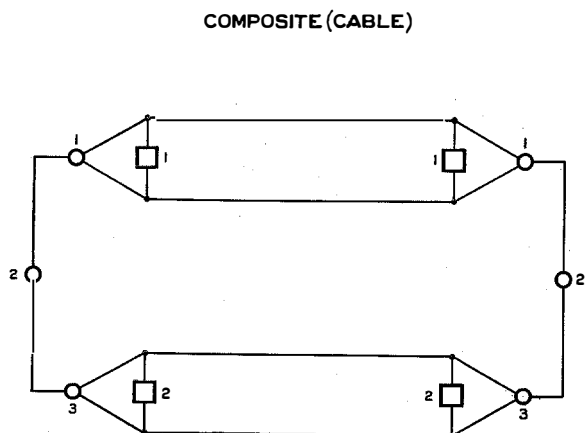

Figure 11



and budgets, nor to make schedules for carrying out works. No one can make new rates and services; all these require prolonged collaboration. No one is in charge of the maintenance; a trouble in one control area may cause great difficulties in that of another, without involving any responsibility on the first.

In ordinary business where the work of a number of people has to be closely co-ordinated to produce success, one of the ways of increasing the efficiency is by comparing the results of districts and divisions, and then devoting attention to the places thus shown to be relatively weak, by this procedure eliminating the weak points and progressively enhancing the efficiency of the strong places. This method of comparison is entirely missing at present and even if weak places were known there is no common machinery for strengthening them, nor indeed any single authority to decide what the treatment should be. Imagine the trunk service in this country if each large trunk area were independent, and if no observations, statistics or information from each of these divisions came to a single authoritative head and therefore common supervision were lacking; or imagine the maintenance of the plant handled independently by each division without any supervision or co-ordination on the part of some central authority. Imagine none of the comparisons, conferences, schools, special instruction, etc., which are employed to screw up efficiency gradually to the highest point within an organization—imagine none of these methods employed in your inland toll service and you form some picture of the International service. In maintenance such matters as studies leading to decreased cost have to be made and the lessons from these studies have to be applied. Examples are comparisons of faults, the length of time circuits are out of order, the number of times circuits are

outside their specified transmission limits. In the Traffic Departments the comparison of Toll observations are important. In all these it is not the adherence to prescribed standards that is so important; it is rather the constant striving after better results assisted by comparisons between divisions which causes a progressive increase in efficiency and improvements in service, and this gradual development of technique and efficiency among very large numbers of persons is one of the very difficult jobs for many businesses.

In the absence of all these things which flow so directly from unity of control, something, of course, would be done and service would result; but it would need a miracle to give it the efficiency of a service supervised and controlled by a competent central authority.

We know that not much, if anything, is gained by increasing the size of any one organization beyond a certain extent. But the individual nations of Europe are far too small to form the economical units for this service, and I cannot escape the conclusion that, sooner or later, there will have to be found some single unit for the administration of the European International service, unless indeed Europe is to rest content with a service relatively much inferior to the plant which she has provided, and I cannot believe that will be the case.

While the first attack on this problem was concerned with physical matters and lay mainly with the engineering departments, the development which has taken place has shifted the point of attack, which now lies largely with the administrative and traffic departments. To-day the problem seems to apply mostly to business matters.

I want particularly to acknowledge the help I have received from Mr. W. J. Hilyer, in dealing with this subject.

# Allocation of European Broadcast Wavelengths —Some New Points of View\*

By SIFFER LEMOINE

*Chief Engineer, Swedish Telegraph Administration*

THE problem of the allocation of wavelengths for the broadcasting stations of Europe has for some considerable time proved a constant source of discussion and the question is, perhaps, more acute than ever at the present time.

The scheme devised at Geneva by *L'Union Internationale de Radiophonie*, which came into operation in November, 1926, and to which most of the broadcasting organisations of Europe have given their adherence, has undoubtedly proved a step in the right direction but, in spite of its defects, it cannot be regarded as representing a final solution to the problem.

Many widely divergent difficulties have hindered the successful execution of the proposals. There are countries and broadcasting organisations who have not conformed to the "Geneva Scheme" and whose stations have been continually changing their wavelengths. These have constituted what might be termed a party of "freebooters of the ether" interfering now with one and now with another of the orthodox stations with results that have naturally been of little service either to themselves or to those affected. Further confusion was also caused by the fact that a number of stations were equipped with old-fashioned installations which were unable to maintain the high degree of accuracy now deemed essential in the maintenance of a constant radio frequency and, indeed, unable to maintain even approximately the wavelengths allotted under the scheme, a difficulty which it is hoped will gradually disappear but of which the effect is at present somewhat annoying. When accurate distribution of wavelengths was first attempted this, more than any other factor, proved the greatest stumbling block, but now it can, to a certain extent, be remedied by fitting one of the wavemeters that have been constructed to meet the requirements of the Union. The

need for absolute constancy of radio frequency is incontestable and should be insisted on more than has hitherto been the case either in connection with the reconstruction of old installations or in the erection of new stations.

During the past twelve months it may be said that this phase in the development of broadcasting has mainly been characterised if not by stagnation at least by a reduction in its progress as compared with former years, due to a certain doubt as to the principles on which its future is to rest and an uncertainty as to what is likely to be permissible or practicable as time goes on. Even where the Geneva Plan has been accepted it has been, in many cases, with a realisation of its imperfection in its present state and in the hope of a revision in the future.

True, some countries have, within the scope of the agreements now in force and without waiting for forthcoming international regulations, managed to increase the power of their stations, but most countries have adopted a cautious attitude, both as regards extending their power and erecting new installations, having in mind especially the question of the principles that might be laid down on this point by the International Radio Conference held at Washington last autumn.

## ***The Resolutions passed by the Washington Conference, and their Significance***

The resolutions passed by the Washington Conference are now known, although there has not yet been time to ratify them. Various wireless services have had their different wavebands allotted—including broadcasting—while the particularly vital question (from the European point of view) of wavelength rights for every country and other principles governing the use of the broadcasting bands has been left open for the present.

It may be said that the result, as far as broadcasting is concerned, has been poorer than had

\* Reprinted by permission from *Experimental Wireless & The Wireless Engineer*.

generally been anticipated. Those zones that have now been assigned for the purpose have been extended in so niggardly a fashion that not only has the growth of the number of stations been stunted but a restriction has been practically laid on those that were previously functioning.

Thus, above 1,000 metres, permission has been granted in Europe to use the zone from 1,875 to 1,550 metres, corresponding to 160–194 kilocycles per second, exclusively for broadcasting and from 1,550 to 1,340 metres (194–224 kc/sec.),

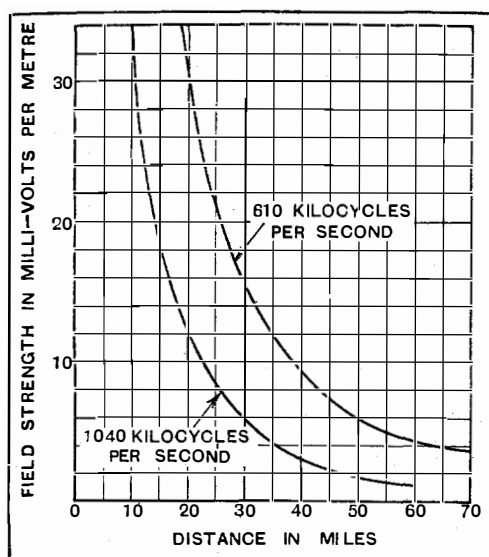

Figure 1

jointly with the air services, but with the proviso that no increase in power may take place so long as disturbances with other traffic may be caused thereby. Below 1,000 metres the limit upwards has been reduced from the present maximum of 600 metres down to 545 metres, while the lower limit has been maintained at 200 metres—corresponding to the kilocycle numbers 550 to 1,500—with the exception of 220 metres (1,365 kc/sec.), which has been allotted exclusively for maritime requirements.

An examination into the significance of these proposals shows that in a way broadcasting finds itself in a more embarrassed situation than before. From having previously been comparatively free from control it has now been confined within a zone amounting in all to no more than 1,014 kilocycles, and this too without taking account of the 220 metres wavelength allotted to

shipping as mentioned above, which will in practice not mean a fixed frequency but a band of considerable breadth. The frequency zones that broadcasting has been granted in addition, comprising lower wavelengths from 50 metres downwards, are at present of no very great importance for the development of normal broadcasting in Europe and in this connection are therefore disregarded.

On the other hand, the resolutions passed in Washington imply a distinct gain, in so far as we are now actually able to say what lines are to be followed. From the point of view of principle, this is more or less of secondary importance, as all countries have conformed to the regulations in question and thus one and all have to come in line with the new order. The resolutions will come into force on the 1st January 1929, except those affecting the higher wavelength zone for broadcasting, for the enforcement of which a further respite of one year has been granted.

The wavelength distribution for which the Geneva Plan has been worked out comprises only the zone from 200 to 600 metres, whereas stations working on other wavelengths have had to rely on their right of priority, which in fact has as a rule been respected. This might have been satisfactory enough at a time when there were no restrictions as to wavelength either upwards or downwards, but as soon as the Washington resolutions come into force, matters will be very different. It is obviously no longer either reasonable or fair to regard the two bands as separate, so that a few privileged countries, actually not more than seven, solely on grounds of priority, may lay claim to the higher wavelengths, while the lower band is allotted on a basis that is independent of the former and to which all are alike entitled. When the allocation is made all frequencies should be included and the question regarded as a whole.

#### *Area and Population as Principles Governing the Distribution of Wavelengths*

Before proceeding further, mention should be made of the principles laid before the Technical Committee of the Union Internationale by the author at the time—principles which, with certain modifications, formed the basis of the distribution now in force. The first of these

contentions was that the number of wavelengths which a country is entitled to possess should be in a fixed proportion to the area of the country. The second proposed that consideration should be given to the size or density of the population.

As regards the first of these principles, it must still be considered to have full force. It may be assumed with approximate accuracy that a broadcasting station of a certain power and with normal equipment has the same range, regardless of the country in which it is erected—there are certainly some exceptions to this, such countries as, for instance, Norway and Switzerland, and part of Sweden, with very mountainous and wooded terrain, are at a disadvantage, whereas on the other hand, the conditions in Holland and Denmark are more favourable than the average. If we take as our basis the idea that every individual, to whatever country he belongs, shall be equally privileged as regards the possibilities of listening-in, the problem of wavelength would be solved simply enough—viz., allotted in proportion to the area of each country. For reasons which will be more closely dealt with later on, however, the time has apparently not yet arrived when we can accept this simply and solley as the basis of distribution; if we are not to lose continuity in the development, we must also give consideration to other factors.

As to the principle of population, the argument produced at the time in favour of this was that the more densely populated areas were better entitled to be supplied with more convenient means of "receiving" than sparsely populated districts, and in consequence certain countries should be allotted a greater number of wavelengths. It may be remembered in this connection that these proposals were made in 1925, that is to say, at a period when the size of the biggest commercial transmitters existing on the market was at the most  $1\frac{1}{2}$  kilowatts. This way of looking at the subject might have been justified at the time by the difficulty of building stations of sufficient power, but nowadays that point of view can hardly be considered tenable, seeing that transmitters of as much as 50 kilowatts and more are now standardised and may be procured at a reasonable price. In certain cases better results and increased efficiency are obtained by the removal of the station to a more suitable locality.

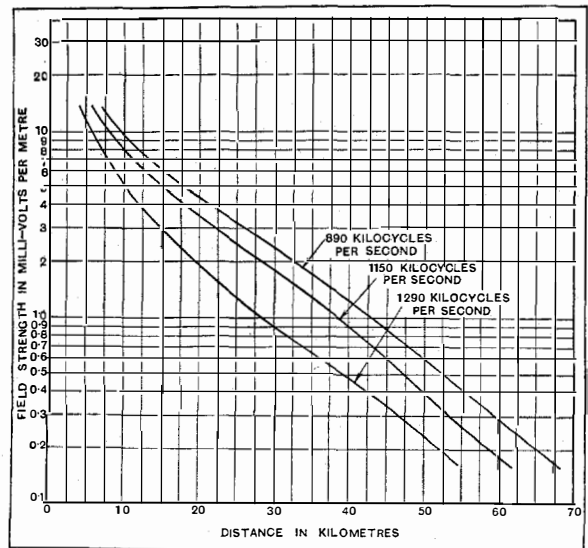

Figure 2

In this connection I venture to quote from the minutes of the meetings of the Union's Technical Committee, held at later dates, a recommendation mentioned in several places and reading as follows: "Fewer stations, greater power"—a principle which is fundamentally quite true and the truth of which, as such, is worthy of being emphasised. It goes without saying that it is in densely populated areas that an outlay of capital for higher-powered transmission will pay best, besides giving the listeners-in within the service area better possibilities of reception, and bringing to the business an increased income from new licence-holders.

#### *Observations on the Question of Modifying the Primary Basis of Distribution*

The question of wavelength distribution must not, however, be viewed merely against a theoretical background; account must also be taken of the position of the present stage of development. The author does not mean by this that the population principle should at once be entirely eliminated, as in certain countries this would involve too sudden a reversal of conditions. A gradual modification is a matter of minor importance and would not seriously inconvenience the broadcasting organisations affected, but enable them to effect the change gradually and without too much friction.

The primary principle that, according to the

author's proposal, should be made the basis of a revised allocation of wavelengths is as follows:

*Every country would obtain the right to a number of wavelengths as corresponding to a function of the country's area and population expressed in percentage, calculated on the basis of area plus one-half the population.*

In Table I a summary has been made according to the latest available official statistics on the areas and populations of the countries of Europe,

to states with a large area but comparatively small density of population. I would emphasise the fact that the table may obviously be adapted to admit of such modifications as may be rendered necessary by special requirements, such as, in particular, unfavourable geographical conditions, polylingual nations, etc., and that, conversely, it may be possible to make certain limitations wherever theoretical deductions have produced abnormally high comparative numbers.

TABLE I

*Comparative Numbers for Wavelength Distribution in Proportion to Superficial Content Area and Population*

Country	Superficial Content (a)		Population (b)		Comparative Numbers	
	100sq. Kms.	%	Mill.	%	a + b/2	%
Albania.....	275	0.52	0.83	0.23	0.635	0.42
Austria.....	838	1.57	6.58	1.83	2.485	1.66
Belgium.....	304	0.57	7.87	2.19	1.665	1.11
Bulgaria.....	1,031	1.94	5.48	1.52	2.700	1.80
Czecho-Slovakia...	1,404	2.63	14.24	3.95	4.605	3.07
Denmark....	429	0.81	3.42	0.95	1.285	0.86
England.....	2,448	4.59	45.21	12.55	10.865	7.24
Esthonia.....	475	0.89	1.12	0.31	1.045	0.70
Finland.....	3,885	7.29	3.29	0.91	7.745	5.16
France.....	5,510	10.34	40.74	11.31	15.995	10.66
Germany.....	4,704	8.82	62.54	17.37	17.505	11.67
Greece.....	1,270	2.38	6.20	1.72	3.240	2.16
Holland.....	408	0.77	7.52	2.09	1.815	1.21
Hungary.....	929	1.74	8.37	2.32	2.900	1.93
Iceland.....	1,028	1.93	0.10	0.03	1.945	1.30
Ireland.....	698	1.31	2.97	0.85	1.735	1.16
Italy.....	3,097	5.81	40.55	11.26	11.440	7.63
Letland.....	658	1.23	1.86	0.52	1.490	0.99
Lithuania....	561	1.05	2.23	0.62	1.360	0.91
Luxemburg...	26	0.05	0.27	0.07	0.085	0.06
Norway.....	3,238	6.08	2.77	0.77	6.465	4.31
Poland.....	3,883	7.29	29.25	8.12	11.350	7.57
Portugal.....	887	1.66	5.62	1.56	2.440	1.63
Roumania....	2,942	5.52	16.98	4.71	7.875	5.25
Spain.....	4,979	9.34	21.62	6.00	12.340	8.23
Sweden.....	4,485	8.42	6.07	1.69	9.265	6.18
Switzerland..	413	0.78	3.94	1.09	1.325	0.88
Yugoslavia...	2,490	4.67	12.49	3.47	6.405	4.27

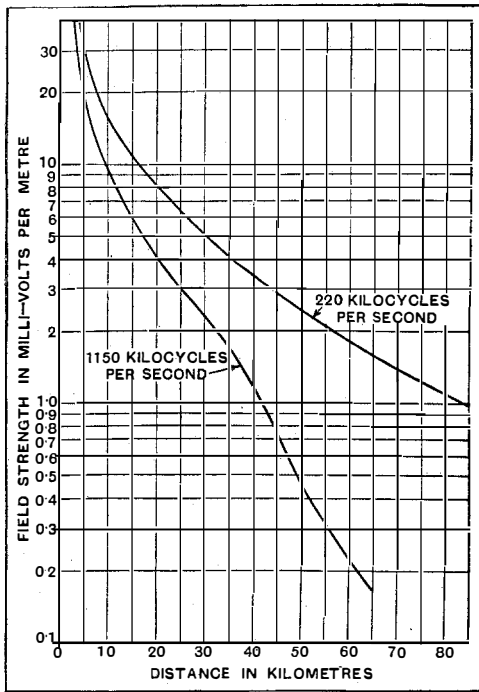

Figure 3

with the exception of Russia and Turkey in Europe. The total area amounts to 5,329,500 sq. kilometres and the population to 361.5 millions. In the last column have been worked out for each country comparative numbers according to the formula  $a + b/2$ , where  $a$  denotes the area and  $b$  the population, both expressed in percentage of the total figures.

If we compare the comparative numbers deduced according to this formula with those obtained if the same value were given both to area and population, we find that only a few unimportant modifications take place slightly to the disadvantage of small and densely populated countries, while corresponding advantages accrue

**Wavelength Allocation According to the Geneva Plan**

For the sake of comparison with the calculation, worked out in Table I, of the new figures proposed as a basis for a revised wavelength distribution, there is given in Table II, as a supplement to the above table, a comprehensive

table of the Plan now in force. After the introduction of a third factor, borrowed from the official statistical information drawn up by the League of Nations regarding the use of the telephone and the telegraph in each country, it was resolved that a distribution should be made among the different countries in accordance with Table II:

This table relates only to the exclusive wavelengths, and Russia has here been excluded from the list, that country not having been represented at the Washington Conference and its attitude towards the question being still unknown. If we examine Table II side by side with Table I, we find agreement in the main, but in certain cases there are considerable differences. Thus, some countries have been allotted, on the Geneva Plan, the same number of wavelengths as others whose area is ten times greater. From a purely technical point of view every one must, of course, admit that the situation of the country that has received a less favourable allotment is fairly hopeless as regards the possibility of carrying on effective broadcasting and that, in such cases, justice and equity demand that a change should be made.

TABLE II

*Wavelength Distribution According to the Geneva Plan*

Country	No. of Exclusive Wavelengths	Country	No. of Exclusive Wavelengths
Albania.....	1	Ireland.....	1
Austria.....	2	Italy.....	5
Belgium.....	2	Letland....	1
Bulgaria.....	1	Lithuania...	1
Czecho-Slovakia...	3	Luxemburg.....	1
Denmark....	1	Norway.....	3
England.....	9	Poland.....	4
Estonia.....	1	Portugal....	1
Finland.....	2	Roumania...	2
France.....	9	Spain.....	5
Germany.....	12	Sweden.....	5
Greece.....	1	Switzerland.....	1
Holland.....	2	Yugoslavia.....	1
Hungary.....	1		
Iceland.....	—		

### ***The Principles for the Mutual Location of the Wavelengths***

The second question of at least equal importance to that of the allocation of the *number* of wavelengths to each country is that of the *mutual*

*location* of stations within the 200–600 metre zone. The number of wavelengths has been based on the principle of a frequency difference between each of 10,000 cycles per sec. Proposals have been brought forward to reduce this difference in order to make room for more stations; it would seem, however, that the time for this has not yet arrived and the present basis of distribution must be maintained for some time longer.

The principles applied in placing the stations have been, in the first place, the so-called polygon procedure, consisting in two stations whose frequencies are of about the same order, being placed at the greatest possible geographical distance apart, as a rule at distances of about 1,000 to 2,000 kms. and, secondly, the acknowledgement of a certain prior right to a previously utilised wavelength. With regard to the polygon method, I shall revert thereto later on in another connection. As to the principle of priority, which should without doubt be given the same value as before, I propose to quote what I wrote on the matter in an earlier report, as follows: "It may be considered reasonable that a station that has for years past been working on one and the same wavelength should be allowed to continue to retain it wherever possible, or, if a change must be made, that this should be done only within such a zone that existing receiving sets within the normal radius of the station need not be altered."

The consequence of this has naturally been that the "better" zone between 300 to 600 metres has been the most sought after and been the first to be utilised, while frequencies below 250 metres have, to a considerable extent, been held as a kind of reserve for future requirements. It may also be regarded as a logical result that countries whose broadcasting has been organised at a later date must in that case be content to use wavelengths within a band that has not previously been occupied.

### ***Proposal for the Introduction of So-called Wavelength Equivalents***

On the other hand, in the author's opinion, an incorrect method has been employed when, in allotting wavelengths, attention has been paid exclusively to the *number* of wavelengths apart

from the question of where they are to be found within the frequency zone, and no consideration has been given to the question of their different service-value. As is well known, a wavelength of 200 metres is, as regards its efficiency, not so desirable as one of 500, wherefore they cannot be compared with one another *qua* wavelengths.

A comparative valuation of different frequencies is justified for two reasons: first, the higher the frequency the greater is the attenuation of a radiated wave; and, secondly, a higher wavelength permits the use of higher masts for the same radiation resistance and consequently gives a greater number of metre-amps. for the same primary power. In consequence of the resolutions passed by the Washington Conference, and since the possibility of a choice of wavelength outside the fixed frequency bands is almost entirely eliminated, the standpoint of equal values is still less justified than before. On the other hand, since it is desirable that the basis of any allocation of wavelengths should be equally applicable to the higher and the lower wavelength zone, the question is whether an acceptable formula can be found for allotting a value to the different frequencies in relation to one another.

Here we have several points of departure to choose from. It is possible to gauge the field-strength at various distances from a given station at different frequencies and when using the same power. Such curves have been published, *inter alia*, by P. P. Eckersley in a recent paper read before *The Institution of Electrical Engineers*, reproduction of which illustration (Fig. 1) has been kindly allowed. Similar results have been obtained in a comparison between measurements of the field-strength from broadcasting stations in Sweden, thus Fig. 2 shows field intensity curves from one and the same station; Fig. 3 similar curves from two different stations, in both cases with approximately the same aerial output. As the measurements in the latter case were taken over land of varying character—actually more favourable to the short-wave station—no direct comparison can be made, but the example shows clearly that there is no small difference in the efficiency of the wavelengths in question.

The object of reproducing these curves is mainly to show that it is not possible by means of measuring to secure a simple and generally applicable expression for the comparative service

value of the wavelengths, chiefly owing to the fact that the field intensity as a rule is dependent on the nature of the ground in each particular case. It seems to be equally improbable to be able to deduce the desired formula on a basis of purely theoretical speculation.

Disregarding therefore the investigations made by the author into the possibilities of using strictly mathematical calculations in the derivation of a suitable formula, the following proposal is submitted: *The service value of one arbitrary wavelength in relation to another within the broadcasting band is calculated as the cube root of the ratio between the inverse values of their frequencies, this value being hereinafter called the wavelength equivalent.*

If for this purpose we choose 300 metres, corresponding to 1,000 kc/sec., as a standard, the desired wavelength equivalent equals the cube root of the quotient between 1,000 and the respective kilocycle number and the calculations will then be easy to work out. In Table III are given the wavelength equivalents, first for the band between 160 and 224 kc/sec. for every 10th kilocycle, secondly for the upper frequency-band for every 100th kilocycle, and in Fig. 4 they are further shown graphically as a function of kc/sec.

TABLE III

*Wavelength Equivalents for Different Frequencies*

Frequency in Kc/sec.	Wavelength in Metres	Wavelength Equivalent	Frequency in Kc/sec.	Wavelength in Metres	Wavelength Equivalent
162	1,852	1.84	700	428.6	1.13
172	1,744	1.80	800	375.0	1.08
182	1,648	1.76	900	333.3	1.04
192	1,563	1.73	1,000	300.0	1.00
202	1,485	1.70			
212	1,415	1.68	1,100	272.7	0.97
222	1,351	1.65	1,200	250.0	0.94
			1,300	230.8	0.92
550	545.6	1.22	1,400	214.0	0.89
600	500.0	1.19	1,500	200.0	0.87

This valuation of higher or lower frequency implies that, for instance, a wavelength between 550 and 500 metres would be regarded as having about 40 percent. greater efficiency than a wavelength of about 200 metres, and further that the wavelengths within the higher band are calculated, on an average, to be 50 to 60 percent more effective than those between 300 and 550 metres.

If we compare the values of the Table with



results obtained by taking measurements, we find that they are throughout a little unfavourable to short-wave stations. It is the view of the author that, to a certain extent, this must actually be the case. The main argument against the introduction of frequency equivalents is that by increasing the power of stations working on lower wavelengths it is possible to counteract the greater attenuation and to obtain an equally long range. This reasoning is correct only within certain limitations. To obtain parity in range between a wavelength of 200 and one of, say, 1,500 metres, would require a power amounting to several hundred kilowatts, with correspondingly heavier establishment and greater running costs. On the other hand, the mathematically less exact agreement and the advantage which the formula gives to the lower frequencies can be compensated without much sacrifice by a smaller increase in the power or often even merely by adopting more suitable arrangements in order to get a better efficiency.

### *Exclusive and Shared Wavelengths*

When the above-mentioned allocation of frequencies between 200 and 600 metres was fixed at Geneva, it was decided that the number of so-called exclusive wavelengths should be 83 and the shared waves 16. It seems in this connection that the question of this distribution should also be taken up for renewed discussion.

The reason for the existence of the shared wavelengths was the need in certain countries for utilising a smaller number of transmitting stations with only a local range. This system has for the present been adopted in most countries. In view of the present establishment the shared wavelengths cannot on that account be removed at once without further notice, but there exist strong reasons for restricting the number, say, from 16 to 12, which in all probability could be done without much inconvenience.

The shared wavelengths have been allocated fairly evenly, being distributed over the entire wavelength band, starting at 588 metres, then at 500, 400, 300 metres, and so on, downwards. An alteration in this arrangement might now profitably be made. Since it was originally the intention that those stations working on shared waves were supposed only to possess a local range and consequently to be equipped with trans-

mitters of comparatively small power—this might be put at approximately not more than 200 watts aerial energy or about 100 metre-amps.—there is no reason why one should set apart for this purpose higher wavelengths that are more serviceable for exclusive use; on the contrary, lower wavelengths are even better adapted for that purpose.

A proposal for a new allocation of the common frequencies is made in Table IV in which the scheme now in force is also given for comparison purpose. All the 12 shared wavelengths proposed are placed below 300 metres, viz., three up to each one of the frequencies 1,100, 1,200, 1,350 and 1,500 kilocycles/sec.

By the adoption of this reduction in the number and re-allocating the shared wavelengths: First, restrictions on the zone 500 to 550 kc/sec. are compensated for; the Washington Conference

TABLE IV

*List of the Present and a Proposal for New Shared Wavelengths*

Present Wavelengths		Proposed Wavelengths	
Frequency in Kc/sec.	Wavelength in Metres	Frequency in Kc/sec.	Wavelength in Metres
510	588.2	1,090	275.2
520	577.0	1,100	272.7
530	566.0	1,110	270.3
600	500.0	1,190	252.1
750	400.0	1,200	250.0
1,010	297.0	1,210	247.9
1,020	294.1		
1,080	277.8	1,350	222.2
		1,360	220.6
1,090	275.2	1,370	219.0
1,100	272.7		
1,180	254.2	1,480	202.7
1,190	252.1	1,490	201.3
		1,500	200.0
1,200	250.0		
1,470	204.1		
1,480	202.7		
1,490	201.3		

prohibits the use of this zone for broadcasting, certain countries, however, being at liberty, wherever possible, to allocate thereto stations of low power, provided that no interference is caused to commercial services. Moreover, the wavelengths of 500, 400 and 300 metres, which have actually proved not very good for joint use, are released as exclusive. Finally, the frequencies around 220 metres, which have at the same time been allotted to marine wireless traffic,

might perhaps conveniently be used by stations having common wavelengths, in cases where the interference from either side may be expected to be negligible.

### ***Application of the Principle of Wavelength Equivalents***

To return to the discussion on the exclusive wavelengths, it has previously been mentioned that the total range of frequencies available for broadcasting amount in all to 1,014 kc/sec., which, allowing for a difference of 10 kilocycles between stations, corresponds to 103 usable frequencies. After deducting the proposed 12 shared wavelengths there thus remain a total of 91 for distribution amongst all the countries of Europe.

It is proposed that the distribution of these should be carried out on the following principle:

*Each country to be allotted that number of frequencies of which the sum of the wavelength equivalents, expressed in percentages, corresponds to the respective comparative numbers given in Table I.*

If we work out the total wavelength equivalents for all frequencies, we obtain, after deducting the shared wavelengths, the number 98.45. From this we must further deduct 1.7 for the big station in Moscow working on about 1,450 metres, which we must take into account for the purposes of this calculation. On wavelengths below 600 metres, on the other hand, there are in Russia at present only a couple of installations of minor importance. The final result will then be 96.75. If, further, we convert the absolute value of each wavelength equivalent in Fig. 4 and express it as a percentage of the total, then the sum of the percentage equivalents of the wavelengths each country is entitled to use will equal the comparative numbers calculated in Table I.

The gist of this is perhaps best explained by means of examples. In the case of most countries the new principle of distribution results in no change. For Great Britain the application of the formula would entail a certain reduction of the wavelengths now provided. Thus, England has, according to Table I, the comparative number 7.24, and with the 10 wavelengths, including Daventry, which are now in use, she would receive an absolute equivalent of 11.27,

corresponding in percentage to 11.65. A strict application of the principle would therefore involve a surrender of a couple of the existing lower exclusive wavelengths. The application of the formula would likewise prove disadvantageous to Sweden and Germany, compared with the present arrangement, while on the other hand, Finland, Italy, Norway, Poland, Spain and Hungary, *inter alia*, would find their position improved. (For possible modifications when the formula is brought into effect, see under final observations.)

### ***Group Allocation of Wavelengths instead of the Polygon Method***

As regards the determination of the frequencies that the various stations must use, the author's view is, as already pointed out, that the principle of priority should still be adhered to as far as is feasible when the distribution is made; concerning the application of the polygon method however, this system might usefully be made the subject of discussion.

As is well known, the radiation from a transmitting station is of two kinds, viz., ground-radiation and space-radiation, of which the former represents the radiation of service to listeners within the normal radius, while the latter as a rule is useful for listeners at very great distances. Experience further goes to show that the space-radiation in the case of the frequencies used in broadcasting returns by reflection to the earth's surface with a maximum of strength at distances of about 1,000 to 2,000 kms., which, when the polygon method is employed, is about equivalent to the distance between two stations of closely related frequencies.

The consequence of this is—and a great many complaints from different quarters testify to the fact—that listeners not infrequently experience great difficulty in distinguishing between the programme of their own station and that of the foreign station next to it in frequency, although it may be remote in point of distance. It is not intended to try in any way to depreciate or disregard the demand for selectivity in receiving sets, but the fact remains that great inconvenience is caused by the present system. There are, for instance, continental stations which, owing to their high power and powerful ether radiation, after nightfall can be heard splendidly

in neighbouring countries within the crystal-range of their own local stations, and even on crystal sets employed for the reception of local stations. Moreover, it may be supposed that

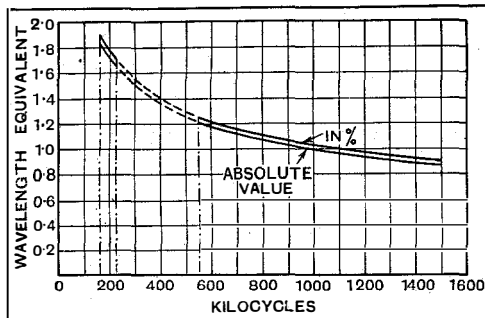

Figure 4

these interferences will be felt in proportion as the number of higher power stations increases.

One way in which the author considers it possible, at least in part, to eliminate this trouble, is to substitute for the polygon method what may most suitably be termed the "group-allocation" of the wavelengths, which would mean that, *if a country possesses the right to several frequencies, these frequencies should be allotted in groups of three or four adjacent bands.*

In this there are at least two advantages to be gained: first, the broadcasting organisation in each country will itself become responsible for the frequencies within each band being kept constant, which would be quite easy when the stations are subordinate to one and the same authority—at the same time the work of the international wavelength control would be lessened—and if they fail in their efforts, their own listeners and not, as is now the case, listeners outside the country, who have nothing to do with the matter, will be the sufferers. Secondly, many of the disturbing effects of the space-radiation would be eliminated, since they would come within a considerably broader frequency-band, and thus listeners to their own local stations will not be troubled by it to such an extent as at present. And a third advantage is that owners of sufficiently selective sets will be afforded better chances of picking up and identifying stations over greater distances. Two stations adjacent in frequency already exist in England, namely, Aberdeen and Daventry Experimental (5GB). Whether or not these disturb one

another in England I do not know, but that they produce interference on the Continent is an acknowledged fact.

It may be added that, as matters stand to-day, the demand for increased transmitting power is often quite as fully justified by the plea of international competition as by the desire of the station to increase its own range. The former way of viewing the matter, which, of course, does not tend to a sound development of broadcasting, would, if the group-allocation of wavelengths were introduced, have less grounds for justification.

### Summary

The views submitted above regarding a revision of the system now in force for allocating the wavelengths of the European broadcasting stations may be summarised as follows:—

(1) That every country shall have the right to such number of frequencies as corresponds to a function of the country's area and population, expressed as a percentage, for which purpose the first factor is taken as the whole, and the latter as half, the numerical value.

(2) That such right shall involve the necessity, before a certain date to be fixed by the Union or other International Conference, of taking into actual use the frequencies allotted, and if this is not done, then, by agreement, such frequencies may be disposed of in some other way, until the International Radio Conference of 1932 determines otherwise.

(3) That all wavelengths that are available within the frequency-bands fixed by the Washington Conference shall be distributed on a common basis.

(4) That the valuation of different frequencies shall be made by the introduction of so-called "wavelength equivalents" on the basis of the formula here drawn up by the author, calculated, in the manner suggested, as the cube-root of the ratio between the inverse values of their frequencies.

(5) That the number of shared frequencies be reduced, to consist of 12 wavelengths instead of the present 16, such stations not being permitted to use more power than 200 watts in the aerial or about 100 metre-amps.

(6) That in the allotment of frequencies to various stations and in the application of the

principle of priority investigations be made into the possibility of introducing a certain "group-allocation" instead of the polygon method.

(7) That such deviations from the principles outlined above may be made as special circumstances require.

### ***Final Observations***

Before closing this article I would like to make a few final remarks and observations. First, then, it may be pointed out that the proposals and views submitted above have not been offered with the idea of procuring for my own or any other country greater advantages than those they have previously enjoyed or may be expected to enjoy in the future, but they represent an attempt to deal with relative questions from an international angle. The object, therefore, is primarily that the views here submitted shall form a basis for a comprehensive enquiry and for further discussion of these problems, and contribute towards giving permanent shape to the international system the foundations of which have been laid by the Geneva Union, and thereby conduce to the continued development of broadcasting.

It may also be emphasised that it is not, in the author's opinion, either possible or expedient to bring these proposals into immediate effect on the strict basis of his theoretical deductions, but, on the contrary, common principles of application are inevitably necessary, exceptions, how-

ever, being made in cases where they are deemed to be justified.

Broadcasting has not developed uniformly in all countries, nor, of course, is it likely to do so in the future. The suppression of what has once been created in favour of newly arisen demands cannot perhaps be avoided in a number of cases, but, on the other hand, it must be admitted that this cannot be done all in a moment; we must keep pace with the discovery of fresh means for solving the problems that arise. Nor can broadcasting afford to let employable frequencies be kept in reserve for an indefinite period; they must be utilised as and when required (point 2 in the summary). At the same time, it is the author's intention, in this article, to give a comprehensive idea of the prevailing conditions and of the difficulties with which broadcasting, regarded internationally, has at present to contend, and also that any claims that may arise must be considered by everyone in their proper light and adjusted accordingly.

Desire has in several quarters been expressed for a revision of the present system with a view to its being brought into line with the resolutions of the Washington Conference. In submitting this article, with the views on the various problems expressed therein and proposals for their solution, the author ventures to express the lively hope that, as these questions may shortly be expected to be taken up for international discussion, his recommendations may happily serve their purpose.



Towers  
and  
Antennae  
System

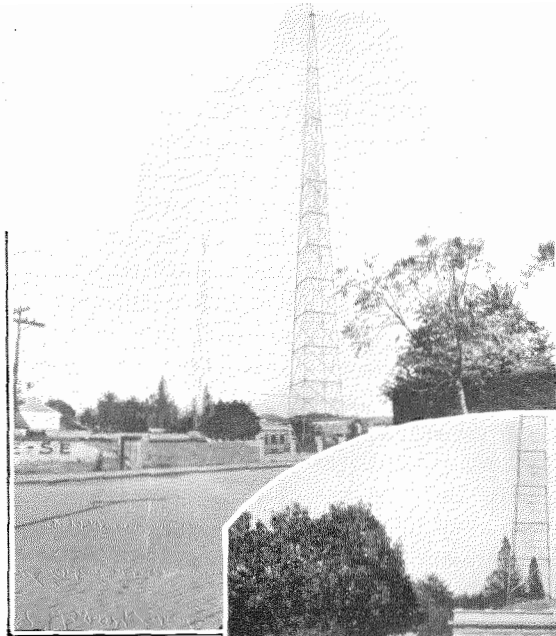

Broadcast-  
ing  
Station

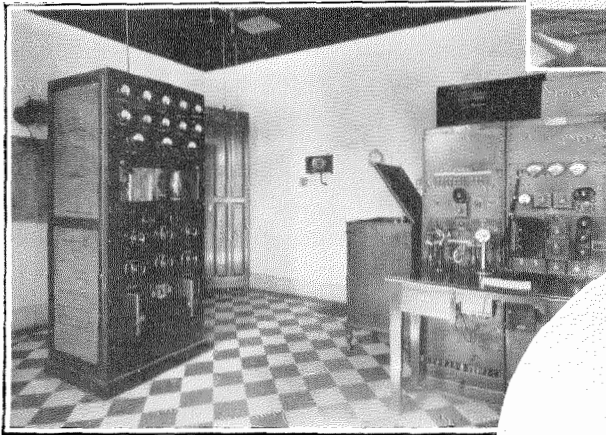

Radio Transmitter  
and Speech  
Input Equipment

Power Room

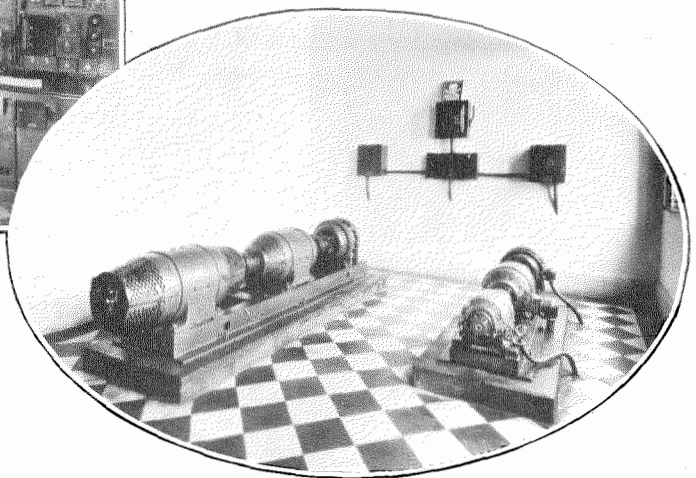

Broadcasting Station SQIG (1 KW). It is owned and operated by Sociedade Radio Educadora Paulista, Sao Paulo, Brazil.

# Sheath Losses In Single-Core Cables For Three-Phase Transmission<sup>1</sup>

By T. N. RILEY

*European Engineering Department, International Standard Electric Corporation*

IN the present state of our knowledge of cable dielectrics, mechanical considerations point to 66,000 volts as the highest transmission pressure for which a three-core cable can be constructed to operate satisfactorily. For three-phase transmission pressures above this it is necessary to use three single-core cables, and with these the circulating currents in the lead sheaths when these are bonded become of importance.

In addition to the circulating current losses there are also eddy current losses in each sheath, but these eddy current losses are always relatively small and, except when the sheaths are in contact, are negligible. The case where the sheaths are in contact, however, is that for which the total sheath losses are least, compared with the copper losses, and, therefore, the neglect of a small component of the sheath losses is of no importance in determining the carrying capacity of the line. They can therefore be neglected in practice.

While accurate mathematical analyses have been made which enable the total losses to be calculated,<sup>2</sup> these lead to complicated formulæ, which are inconvenient for practical use; and, on account of normal manufacturing variations, do not give more accurate practical forecasts than simpler approximate formulæ. The sheath thickness, for example, may vary from the mean value assumed, and the spacing cannot be absolutely constant under practical conditions of laying.

The following analysis leads to simple formulæ which can be easily applied, and which give results checking closely with experimental values.

## Single-Phase Transmission

When two lead-sheathed cables are used for single-phase transmission, if  $M$  is the mutual

<sup>1</sup> Reprinted, with modifications and acknowledgements, from the *Journal of the Institution of Electrical Engineers*, Vol. 65, No. 371, November 1927.

<sup>2</sup> Dwight, *Electric Journal*, 1924, Vol. 21, p. 62. Carter, *Camb. Phil. Mag.*, Vol. XXIV, Part 1, p. 65, 1928.

inductance between the core loop and the sheath loop, and  $I$  is the current in the core, the e.m.f. induced in the sheath is  $M\omega I$ , where  $\omega$  is  $2\pi \times$  frequency.

Capdeville gives

$$M = \left[ 1 - \frac{2e^2}{f^2 - e^2} \log_e \frac{f}{e} + 2 \log_e \frac{d}{f} \right]$$

absolute units per unit length,

where  $d$  is the distance between cable centers, and  $e$  and  $f$  are the inner and outer radii of the sheath respectively. The mathematical derivation of this formula is given in full in the original paper, and also in Messrs. Melsom and Beer's paper on "The Current Rating of Single-Conductor, Lead-Covered, Low-Tension Cables on Single-Phase Alternating-Current Circuits."<sup>3</sup> It is not there-

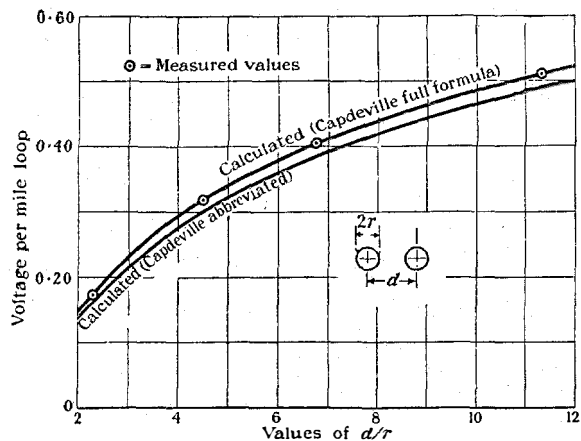

Figure 1—Sheath Voltages Induced in Two Single-core Cables per Ampere of Core Current at 50 Cycles per Sec. The values shown are mean values of tests from 10 to 300 amperes.

fore necessary to reproduce it here. As Fig. 1 shows, this formula gives a result which agrees exactly with experiment, but as the first two terms very nearly cancel each other it is a sufficiently close practical approximation to take  $M = 2 \log_e \frac{d}{f}$  absolute units per unit length of circuit.

<sup>3</sup> *Journal I. E. E.*, 1295, Vol. 63, p. 199.

Reduced to practical units this becomes

$$M = \frac{1.48}{10^3} \log_{10} \frac{d}{r} \text{ henrys per loop mile}$$

where  $r$  is used instead of  $f$  for the sheath outer radius.

In making calculations in the three-phase case, therefore, the abbreviated form of Capdeville's formula has been taken for simplicity, though the general formulæ developed are correct for any value of the mutual inductance.

**Three-Phase Transmission**

A three-phase transmission line consisting of horizontally spaced single-core cables can be con-

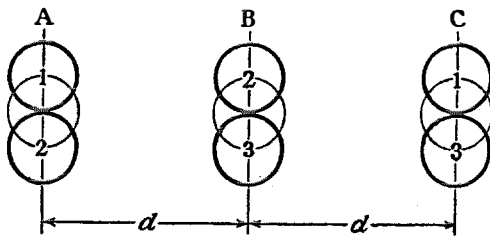

Figure 2—Three-phase Line Split into Three Single-phase Sections.

sidered as split up into three sections as indicated in Fig. 2, each of which forms a single loop having conductors of the same dimensions as the original cables.

The currents in the original phases A, B and C can be considered as being made up of the following currents in the separate loops:

$$\begin{aligned} i_1 &= i \sin \theta \\ i_2 &= i \sin \left( \theta + \frac{2\pi}{3} \right) \\ i_3 &= i \sin \left( \theta - \frac{2\pi}{3} \right) \end{aligned}$$

The original current in phase A is then

$$i_A = i_1 - i_2 = \sqrt{3}i \sin \left( \theta - \frac{\pi}{6} \right)$$

in phase B

$$i_B = i_2 - i_3 = \sqrt{3}i \sin \left( \theta + \frac{\pi}{2} \right)$$

and in phase C

$$i_C = i_3 - i_1 = \sqrt{3}i \sin \left( \theta + \frac{7\pi}{6} \right)$$

The phase relationships of these currents are shown in Fig. 3.

Let

- $M_1$  = mutual inductance between core 1 and sheath 1.
- $M_2$  = mutual inductance between core 2 and sheath 2.
- $M_3$  = mutual inductance between core 3 and sheath 3.

For the usual symmetrical spacing as shown in Fig. 2,  $M_3 = M_2$ , and, for simplicity, this case only is considered below, though the principle of the calculation can be applied also to unequal spacings.

When the dimensions are small compared with the spacings, as is usually the case in practice for flat spacings, it is clear from symmetry that sheath 2 will be linked with exactly half the magnetic flux which links sheath 1 due to a current in core 1. The mutual inductance of sheath 2 with core 1 will, therefore, be half the mutual inductance of sheath 1 with core 1, i.e., it will be  $\frac{1}{2}M_1$ . Similarly, since there can only be one value of the mutual inductance between two circuits,  $\frac{1}{2}M_1$  is also a measure of the flux produced by unit current in sheath 2 which is linked with core 1. What we need, however, is a measure of the flux produced by unit current in core 2 which is linked with sheath 1. Now

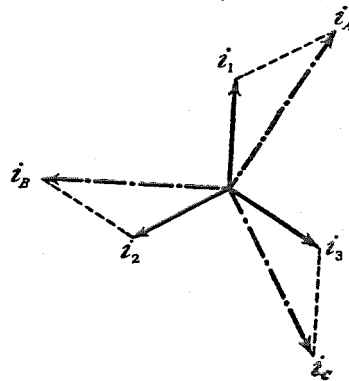

Figure 3—Vector Diagram Showing Phase Relationship of Currents in Three-phase Line and Single-phase Sections.

unit currents in core 2 or sheath 2 will produce the same field external to the sheath, but unit current in the core produces an additional flux between core and sheath. This flux, however, is not linked with sheath 1 either, so that the mutual inductance between core 2 and sheath 1

is also  $\frac{1}{2}M_1$ . But the total flux produced by unit current in core 2 which is linked with sheath 2 is proportional to  $M_2$ , and if this flux is not also to link sheath 1 it must return inside sheath 3, so that the difference of the quantities  $M_2$  and  $\frac{1}{2}M_1$  is a measure of the flux due to unit current in core 2 which links sheath 3, i.e.,  $M_2 - \frac{1}{2}M_1$  is the mutual inductance between core 2 and sheath 3. It is similarly the mutual inductance between core 3 and sheath 2.

This can easily be demonstrated by circulating an alternating current in cores A and B only and measuring the induced e.m.f.'s at the near end of each of the loops formed by the three lead sheaths when bonded at the far end. That between the sheaths of A and B will be proportional to  $M_2$ , that between A and C will be proportional to  $\frac{1}{2}M_1$ , and that between B and C will be proportional to  $M_2 - \frac{1}{2}M_1$ .

Consider first the e.m.f.'s induced in sheath 1 by the currents in the cores.

The e.m.f. induced in sheath 1 due to current in core 1

$$= M_1\omega i_1.$$

The e.m.f. induced in sheath 1 due to current in core 2

$$= -\frac{1}{2}M_1\omega i_2.$$

The e.m.f. induced in sheath 1 due to current in core 3

$$= -\frac{1}{2}M_1\omega i_3.$$

The total e.m.f. in the loop formed by the sheaths of circuit 1 is the sum of the above

$$= M_1\omega i_1 - \frac{1}{2}M_1\omega i_2 - \frac{1}{2}M_1\omega i_3.$$

Substituting the values of  $i_1$ ,  $i_2$  and  $i_3$  we have

$$e_{S1} = M_1\omega i \sin \theta - \frac{M_1}{2} \omega i \sin \left( \theta + \frac{2\pi}{3} \right) - \frac{M_1}{2} \omega i \sin \left( \theta - \frac{2\pi}{3} \right) = \frac{3}{2} M_1\omega i \sin \theta. \quad (1)$$

Similarly we have for the loop formed by the sheaths of circuit 2,

$$e_{S2} = M_2\omega i_2 - \left( M_2 - \frac{M_1}{2} \right) \omega i_3 - \frac{M_1}{2} \omega i_1,$$

which on substitution reduces to

$$e_{S2} = \sqrt{3}\omega i \left\{ \left( M_2 - \frac{M_1}{4} \right) \cos \theta - \frac{\sqrt{3}}{4} M_1 \sin \theta \right\}, \quad (2)$$

and for the loop formed by the sheaths of circuit 3,

$$e_{S3} = \sqrt{3}\omega i \left\{ - \left( M_2 - \frac{M_1}{4} \right) \cos \theta - \frac{\sqrt{3}}{4} M_1 \sin \theta \right\}. \quad (3)$$

Reverting now to the actual condition of three single sheaths, let us consider the currents set up in the sheaths by these e.m.f.'s. Fig. 4 shows diagrammatically the relationship of the circulating currents and induced e.m.f.'s, the cores being separated into three planes for clearness. The end bonds ABC and A'B'C' are supposed to have no resistance.

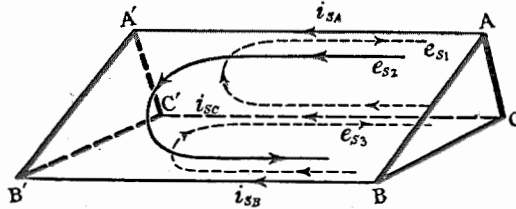

Figure 4—Diagram Illustrating Circulating Currents and e.m.f.'s in Sheaths of Three Single-core Cables.

The inductances of the sheaths on unarmoured cables are usually negligibly small compared with the resistances, and the impedances of the sheaths are approximately equal. Suppose, however, in the first instance, that they are not equal and that

$Z_O$  = impedance of each outer

$Z_M$  = impedance of center sheath.

Then for the loop CC'A'A (loop 1)

$$e_{S1} = i_{SC}Z_O - i_{SA}Z_O,$$

for the loop AA'B'B (loop 2)

$$e_{S2} = i_{SA}Z_O - i_{SB}Z_M,$$

and for the loop BB'C'C (loop 3)

$$e_{S3} = i_{SB}Z_M - i_{SC}Z_O,$$

also

$$i_{SA} + i_{SB} + i_{SC} = 0.$$

From these equations it follows that

$$i_{SA} = \frac{e_{S2}Z_O - e_{S1}Z_M}{Z_O(Z_O + 2Z_M)},$$

$$i_{SB} = \frac{e_{S3} - e_{S2}}{Z_O + 2Z_M},$$

$$i_{SC} = \frac{e_{S1}Z_M - e_{S3}Z_O}{Z_O(Z_O + 2Z_M)}.$$



Inserting the values of the sheath e.m.f.'s [equations (1), (2) and (3)] we have

$$i_{SA} = \frac{\sqrt{3\omega i}}{2Z_M} \left\{ \left( M_2 - \frac{M_1}{4} \right) \left( \frac{2Z_M}{Z_0 + 2Z_M} \right) \cos \theta - \frac{\sqrt{3M_1}}{2} \cdot \frac{Z_M}{Z_0} \sin \theta \right\},$$

$$i_{SB} = -\frac{\sqrt{3\omega i}}{2Z_M} \left\{ \left( 2M_2 - \frac{M_1}{2} \right) \left( \frac{2Z_M}{Z_0 + 2Z_M} \right) \cos \theta \right\},$$

$$i_{SC} = \frac{\sqrt{3\omega i}}{2Z_M} \left\{ \left( M_2 - \frac{M_1}{4} \right) \left( \frac{2Z_M}{Z_0 + 2Z_M} \right) \cos \theta + \frac{\sqrt{3M_1}}{2} \cdot \frac{Z_M}{Z_0} \sin \theta \right\}.$$

If  $Z_0 = Z_M = Z$  the formulæ become

$$i_{SA} = \frac{\sqrt{3\omega i}}{3Z} \left\{ \left( M_2 - \frac{M_1}{4} \right) \cos \theta - \frac{3\sqrt{3M_1}}{4} \sin \theta \right\}. \tag{4}$$

$$i_{SB} = -\frac{\sqrt{3\omega i}}{3Z} \left\{ \left( 2M_2 - \frac{M_1}{2} \right) \cos \theta \right\}. \tag{5}$$

$$i_{SC} = \frac{\sqrt{3\omega i}}{3Z} \left\{ \left( M_2 - \frac{M_1}{4} \right) \cos \theta + \frac{3\sqrt{3}}{4} M_1 \sin \theta \right\}. \tag{6}$$

current, the sheath current will be

$$i_3 = \frac{\sqrt{3\omega i}}{2Z} M \sin \theta.$$

For purposes of direct comparison it is convenient to write the actual sheath currents in the same form with the denominator  $2Z$  instead of  $3Z$ . The equations then become:

$$i_{SA} = \frac{\sqrt{3\omega i}}{2Z} \left\{ \left( \frac{2M_2}{3} - \frac{M_1}{6} \right) \cos \theta - \frac{\sqrt{3}}{2} M_1 \sin \theta \right\}, \tag{7}$$

$$i_{SB} = -\frac{\sqrt{3\omega i}}{2Z} \left\{ \left( \frac{4M_2}{3} - \frac{M_1}{3} \right) \cos \theta \right\}, \tag{8}$$

$$i_{SC} = \frac{\sqrt{3\omega i}}{2Z} \left\{ \left( \frac{2M_2}{3} - \frac{M_1}{6} \right) \cos \theta + \frac{\sqrt{3}}{2} M_1 \sin \theta \right\}. \tag{9}$$

The maximum value of currents  $i_{SA}$  and  $i_{SC}$  is

$$\frac{\sqrt{3\omega i}}{2Z} \sqrt{\left[ \left( \frac{2M_2}{3} - \frac{M_1}{6} \right)^2 + \frac{3}{4} M_1^2 \right]}.$$

The sheath losses are proportional to the squares of the current values, and in the form to which the latter have been reduced a direct comparison with the single-phase case can be

TABLE 1

1	2	3	4	5	6	7	8	9
$\frac{d}{r}$	$\log_{10} \frac{d}{r}$	$\log_{10} \frac{2d}{r}$	$M_2$	$M_1$	$\sqrt{\left[ \left( \frac{2M_2}{3} - \frac{M_1}{6} \right)^2 + \frac{3}{4} M_1^2 \right]}$	$\left( \frac{4M_2}{3} - \frac{M_1}{3} \right)$	Equivalent $M$	Equivalent Delta Spacing
2	0.301	0.602	0.466	0.892	0.798	0.2968	0.664	1.41 $d$
3	0.477	0.778	0.706	1.154	1.038	0.556	0.906	1.36 $d$
4	0.602	0.903	0.892	1.336	1.216	0.744	1.08	1.34 $d$
6	0.778	1.079	1.154	1.596	1.474	1.004	1.336	1.325 $d$
8	0.903	1.204	1.336	1.784	1.656	1.184	1.516	1.315 $d$
12	1.079	1.38	1.596	2.04	1.914	1.444	1.770	1.305 $d$
16	1.204	1.506	1.784	2.22	2.096	1.64	1.956	1.3 $d$

Since  $Z_0$  is greater than  $Z_M$  it is clear that the effect of greater impedance in the outers is to cause a slight reduction of the total loss which will be more marked on the outers than in the center sheath since the second term is the preponderating one in the expressions for the currents in the outers.

In the single-phase case with the same spacing as that between outer and middle, and a current  $\sqrt{3i}$  in the cores, i.e., the actual three-phase

made by comparing the squares of the mutual inductance coefficients. In this way an equivalent single spacing can be estimated from which the losses can be easily calculated (see Table 1).

For practical purposes it is sufficiently accurate to take the mutual inductance between core and sheath of a single loop of unarmoured cable as

$$M = \frac{1.48}{10^3} \log_{10} \frac{d}{r} \text{ henrys per mile loop,}$$

where  $d$  is the distance between core centers and  $r$  is the sheath radius.

The loss in the case of delta spacing at distance  $d$  (see below) is proportional to the square of col. 4. For flat spacing the loss in each outer is proportional to the square of col. 6, and that in the middle sheath is proportional to the square of col. 7. The total loss is proportional to the square of the value of  $M$  given in col. 8, which is the square root of one-third of the sum of twice the square of col. 6 plus the square of col. 7. Col. 9 is the delta spacing which would give the value of  $M$  in col. 8.

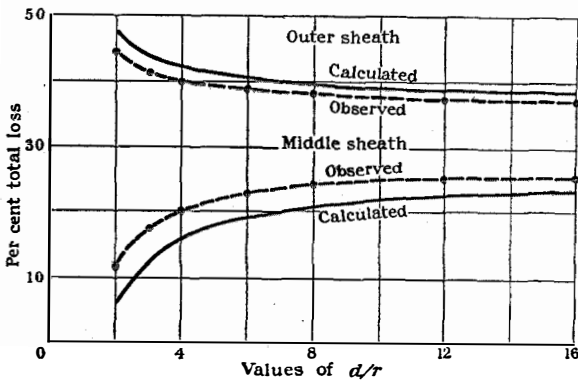

Figure 5—Calculated and Observed Proportions of Total Sheath Losses Occurring in Each Sheath of Three Single-core Cables with Flat Spacing.

The value of  $d/r = 2$  corresponds to the sheaths touching, which is closer than would normally occur in practice. On the other side the spacing will rarely be so great that  $d/r$  exceeds 12, and for most cases it will give a sufficiently close approximation if an equivalent value of  $d$  of 1.33 times the distance between adjacent cores is taken. The total loss for flat spacing will then be three times the single-phase loss per sheath calculated with this spacing and the normal line current.

The total losses are divided between the three cores as follows:

$\frac{d}{r}$	Outer Sheaths, Each, Per Cent	Centre Sheath, Per Cent
2	46.7	6.6
3	43.7	12.6
4	42.0	16.0
6	40.6	18.8
8	39.8	20.4
12	39.0	22.0
16	38.2	23.6

These values are plotted in Fig. 5.

### Delta Spacing

It is of interest to note that the special case of delta spacing with three equidistant cores can be obtained directly from the above by writing

$$M_1 = M_2 = M.$$

We then have for the value of the e.m.f.'s in the sheaths:

$$e_{S1} = \frac{3}{2} M \omega i \sin \theta,$$

$$e_{S2} = \frac{3}{2} M \omega i \sin \left( \theta + \frac{2\pi}{3} \right),$$

$$e_{S3} = \frac{3}{2} M \omega i \sin \left( \theta - \frac{2\pi}{3} \right).$$

It is clear by inspection that the induced e.m.f.'s in the loop are  $\frac{1}{2}\sqrt{3}$  times those which would be obtained on the single-phase loop formed by taking any two of the cores. This corresponds to the same induced voltage per single sheath as in the single-phase case, since the circulating currents in the three sheaths will differ in phase by  $120^\circ$ .

This may be illustrated from two of the tests given in Dunsheath's paper.<sup>4</sup> Mr. Dunsheath has been good enough to furnish the author with his cable dimensions and test-results. The manner in which values calculated as above compare with measured ones is shown in Tables 3 and 4.

TABLE 3

Dunsheath's Fig. 5. Current 160 amps.  
Voltage per Single Sheath on Separate Single-Core Cables

Spacing.....	1 in.	2 in.	3 in.	4 in.	5 in.	6 in.
Calculated value.....	1.01	1.27	1.48	1.64	1.78	1.905
Test-result.....	1.006	1.243	1.423	1.563	1.635	1.963

TABLE 4

Dunsheath's Fig. 8. "S. L." Cable  
Near End Open-Circuit Voltage with Far End Bonded

Current, in amps.....	100	150	208	255	300
Test value.....	0.75	1.05	1.1	1.55	1.95
Calculated value (full Capdeville formula)	0.593	0.89	1.24	1.51	1.79
Calculated value (approximate formula)	0.545	0.82	1.135	1.39	1.64

<sup>4</sup> Jour. Inst. E. E., 1927, Vol. 65, p. 476.

These figures are better compared in Fig. 6, where they are plotted.

Returning now to the calculation of the current, we have, by substituting  $M_1 = M_2 = M$  in

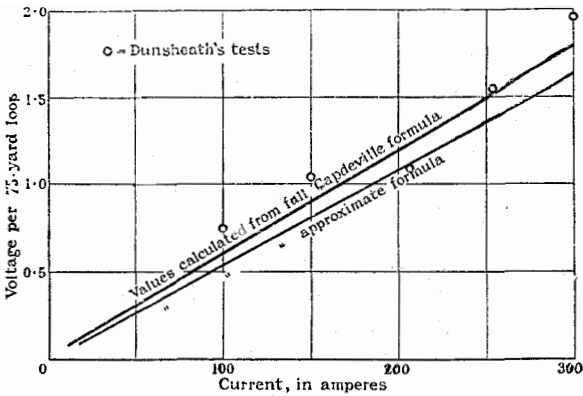

Figure 6—Comparison of Calculated Values of Sheath Loss with Those Quoted by Mr. Dunsheath in Fig. 8 of His Paper.

equations (7), (8) and (9),

$$i_{SA} = \frac{\sqrt{3M\omega i}}{2Z} \sin\left(\theta + \frac{5\pi}{6}\right),$$

$$i_{SB} = \frac{\sqrt{3M\omega i}}{2Z} \sin\left(\theta - \frac{\pi}{2}\right),$$

$$i_{SC} = \frac{\sqrt{3M\omega i}}{2Z} \sin\left(\theta + \frac{\pi}{6}\right),$$

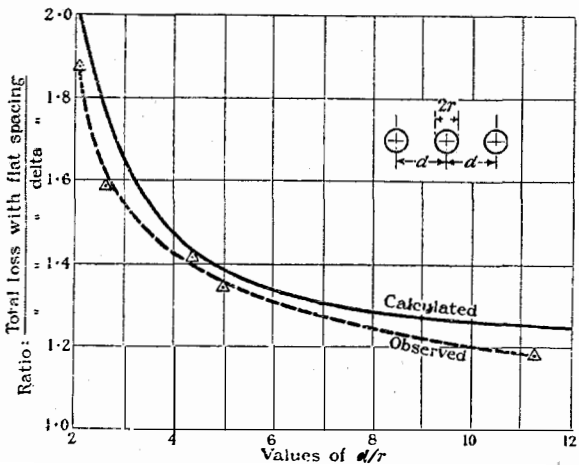

Figure 7—Ratio of Total Sheath Loss in Three Single-core Cables with Flat Spacing to Sheath Loss with Delta Spacing.

the maximum value in each case being the same as would be obtained in the single-phase case.

Experiments have been carried out to check these results, and the comparative measured and calculated results are shown in Figs. 7 and 8. The calculations in this case are based on the

theoretical values determined as in Table 1.

Fig. 7 shows the ratio of the total sheath losses in the three cores to the loss which would occur if the three cables were equally spaced at the distance between two adjacent cables.

Fig. 8 shows the ratio of the sheath losses in each outer cable and in the middle cable to the loss which would occur in each of three cables equally spaced at the distance between two adjacent cables. It will be noted that the total loss is in general slightly less than that calculated and that the center core loss is rather higher and the outer core losses rather less than the calculated values. This is to be expected, since the inductance of the sheath circuit has been ignored

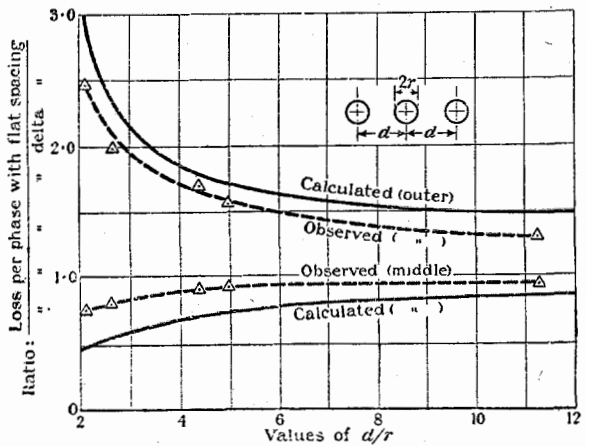

Figure 8—Ratio of Sheath Losses in Each of Three Single-core Cables with Flat Spacing to Single Sheath Loss with Delta Spacing.

in determining the actual circulating currents, and this would slightly reduce the current and therefore the total loss. It would have a more marked effect on the outers than on the middle core. For two adjacent cables the reactance was of the order of one-sixth the ohmic resistance, but for the two outers at the smallest spacing it was of the order of one-third the total resistance, and its effect begins to be appreciable. It would tend to reduce the proportion of the loss in the outer cores and to increase the proportion of the loss in the middle core. Over the practical range the loss in the outers is from 1.5 to 2.5 times that in the middle core.

In order to show how closely the measured values compare with those calculated on the assumption of an equivalent spacing of  $1.33d$ , the values shown in Table 5 have been calculated.

It will be noted that, considering the short length on which tests were made and the consequent difficulty in eliminating end-effects, the agreement is exceptionally good, and the method of calculation is sufficiently accurate to involve no appreciable error in estimated loadings.

In order to make the method perfectly clear the full calculation is given below for one position of the cables tested. These were three 25-yard lengths of 0.25 sq. in. single-core cables with a sheath 1.55 in. inside and 1.75 in. outside diameter. The sheath resistance per 25-yard length was 0.0129 ohm, the core resistance 0.00255 ohm and the core current 100 amps. Frequency = 50 periods. Distance between centers 3.82 in., so that  $d/r = 4.36$ .

$$= M\omega I = 1.6 \times 10^{-5} \times 314 \times 100$$

$$= 0.503 \text{ volt (loop).}$$

$$\text{Equivalent current} = \frac{0.503}{2 \times 0.0129} = 19.5 \text{ amps.}$$

$$\text{Total loss} = 3 \times (19.5)^2 \times 0.0129 = 14.7 \text{ watts.}$$

Of this total we can determine from the calculated curves in Fig. 5 what proportion of losses occur in each phase. This gives us approximately 6.15 watts in each outer and 2.4 watts in the center sheath. The actual distribution of the losses is a little less in the outers and rather more in the center. Taking, however, the calculated value, we have a sheath loss in each outer of 24 per cent of the copper loss, which, allowing for the fact that the heat has not to pass through

TABLE 5  
Sheath Circuit Loss per 100 Amps. Core Current  
Three-Phase Flat Spacing. 25 Yards Length

$\frac{d}{r}$	Single-phase		Three-phase						
	One Leg of Circuit		Each Outer		Middle		Total Loss		Copper Loss
	Measured	Calculated	Measured	Calculated	Measured	Calculated	Measured	Calculated	Total
2.11	1.085	0.885	2.65	2.35	0.81	0.39	6.10	5.1	76.5
2.67	1.55	1.53	3.1	3.31	1.22	0.83	7.4	7.45	76.5
4.36	3.63	3.48	6.1	6.15	3.1	2.40	15.3	14.7	76.5
4.91	4.25	4.0	6.7	6.99	3.7	2.92	17.1	16.9	76.5
11.2	8.8	9.35	11.6	13.7	7.85	7.6	31.0	35.0	76.5

For the single-phase case we have

$$M = \frac{1.48}{10^3} \log_{10} \frac{d}{r} = \frac{1.48}{10^3} \log_{10} \frac{3.82}{0.875}$$

$$= \frac{0.948}{10^3} \text{ henry per mile loop,}$$

or  $1.35 \times 10^{-5}$  henry per 25-yard loop.

Induced voltage in sheath

$$= M\omega I = 1.35 \times 10^{-5} \times 314 \times 100$$

$$= 0.425 \text{ volt (loop).}$$

$$\text{Current} = \frac{0.425}{2 \times 0.0129} = 16.4 \text{ amps.}$$

$$\text{Watts lost per single sheath} = (16.4)^2 \times 0.0129$$

$$= 3.48 \text{ watts.}$$

For the three-phase case we have:

$$\text{Equivalent } M = \frac{1.48}{10^3} \log_{10} \frac{1.33d}{r}$$

$$= \frac{1.13}{10^3} \text{ henry per mile loop,}$$

or  $1.6 \times 10^{-5}$  henry per 25-yard loop.

Equivalent induced voltage in sheath

the dielectric, would reduce the current-carrying capacity about 10 per cent. Comparing the current loading of the three spaced cables with that of a three-core cable, however, the heating due to the sheath losses is more than compensated for by the extra cooling effect due to wider spacing, and up to the limit of practical spacings the single-core cables run cooler. Dunsheath<sup>5</sup> shows in his Figs. 15 and 18 that 0.2 sq. in. single-core cables at 6 in. spacing run cooler than at 2.1 in. spacing, and the latter slightly cooler than a three-core cable. For 0.5 sq. in. low-tension cables Melsom and Beer<sup>6</sup> show a slight increase in permissible loading as the cables are separated, followed by a drop again owing to increased loss when  $d/r$  is greater than 15. The maximum current-carrying capacity in this case was reached for  $d/r = 6$ .

The experimental work the results of which are quoted in the paper has been carried out in the research laboratories of Messrs. Standard Telephones and Cables, Ltd.

<sup>5, 6</sup> *Loc. cit.*

---

---

# *International Standard Electric Corporation*

*Head Offices*  
NEW YORK, U. S. A.

*European General Offices*  
LONDON, ENGLAND  
PARIS, FRANCE

## *Associated and Allied Companies*

- Standard Telephones and Cables, Limited.....*Aldwych, London, England*  
Branches: Birmingham, Glasgow, Leeds, Liverpool, Manchester,  
Dublin, Cairo, Johannesburg, Calcutta, Singapore.
- Standard Telephones and Cables (Australasia), Ltd.....*Sydney, Australia*  
Branches: Melbourne, Wellington.
- Bell Telephone Manufacturing Company.....*Antwerp, Belgium*  
Branches: Berne, The Hague, Brussels.
- Standard Electric Doms a Spolecnost.....*Prague, Czecho-Slovakia*
- Standard Electrica, S. A.....*Madrid, Spain*
- Standard Elettrica Italiana.....*Milan, Italy*  
Branch: Rome.
- Standard Electric Aktieselskap.....*Oslo, Norway*
- Le Materiel Telephonique.....*Paris, France*
- United Telephone and Telegraph Works, Ltd.....*Vienna, Austria*  
Branch: Tallinn (Reval).
- Standard Electric Company w. Polsce.....*Warsaw, Poland*
- Standard Villamossagi R/T.....*Ujpest, near Budapest, Hungary*
- Compania Standard Electric Argentina.....*Buenos Aires, Argentina*
- International Standard Electric Corporation, Branch Office.  
*Rio de Janeiro, Brazil*
- Nippon Electric Company, Limited.....*Tokyo, Japan*  
Branches: Osaka, Dalny, Seoul, Taihoku.
- Sumitomo Electric Wire & Cable Works, Limited.....*Osaka, Japan*
- China Electric Company, Limited.....*Peking, China*  
Branches: Shanghai, Tientsin, Canton, Mukden.

Sales Offices and Agencies Throughout the World

To those interested in better communication the International Standard Electric Corporation and its Associated and Allied Companies offer the facilities of their consulting engineering departments to aid in the solution of problems in Telephony, Telegraphy and Radio.